

# After Action Report

## Training Exercise at Fort Irwin

### October 20 – November 2, 2019

### Battle for Atropia

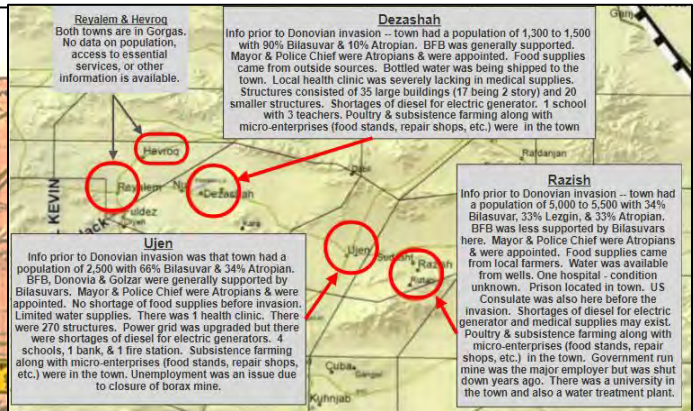
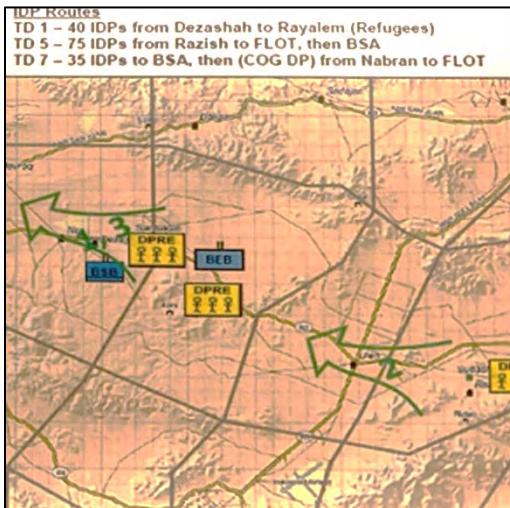

Michael Maxey  
[Michael@Maxey.Info](mailto:Michael@Maxey.Info)  
 703-888-9143

## Acronyms

<b>AHA</b>	<b>-----</b>	<b>All Hands Atropia</b>
<b>BCT</b>	<b>-----</b>	<b>Brigade Combat Team</b>
<b>BFB</b>	<b>-----</b>	<b>Bilasuvar Freedom Brigade</b>
<b>CAT</b>	<b>-----</b>	<b>Civil Affairs Team</b>
<b>CCHF</b>	<b>-----</b>	<b>Crimean-Congo Hemorrhagic Fever</b>
<b>CMOC</b>	<b>-----</b>	<b>Civil-Military Operations Center<sup>1</sup></b>
<b>DATT</b>	<b>-----</b>	<b>Defense Attaché</b>
<b>DCs</b>	<b>-----</b>	<b>Displaced Civilians</b>
<b>DCM</b>	<b>-----</b>	<b>Deputy Chief of Mission</b>
<b>IA</b>	<b>-----</b>	<b>Inter-Agency</b>
<b>IDPs</b>	<b>-----</b>	<b>Internally Displaced Persons</b>
<b>NEO</b>	<b>-----</b>	<b>Non-Combatant Evacuation Operation</b>
<b>PDO</b>	<b>-----</b>	<b>Public Diplomacy Officer</b>
<b>RTU</b>	<b>-----</b>	<b>Rotational Training Unit</b>
<b>SME</b>	<b>-----</b>	<b>Subject Matter Experts</b>
<b>SOC</b>	<b>-----</b>	<b>Special Operations Command</b>
<b>UNH</b>	<b>-----</b>	<b>United Nations High Commission on Refugees</b>
<b>USAID</b>	<b>-----</b>	<b>United States Agency for International Development</b>
<b>USG</b>	<b>-----</b>	<b>United States Government</b>
<b>USSOCOM</b>	<b>-----</b>	<b>United States Special Operations Command</b>

---

<sup>1</sup> The CMOC facilitates operations between the civil environment and military forces conducting operations within a given Area of Operation (AO). The CMOC provides a place where stakeholders can coordinate their activities as unified action partners. See <https://irp.fas.org/doddir/army/atp3-57-70.pdf> - "Joint operations recognize that military forces alone are not the only actors in an OE. Commanders must leverage the interests and capabilities of the civil component to achieve unified action. Army forces conduct unified land operations to synchronize, coordinate, and integrate the activities of governmental and nongovernmental entities to achieve unity of effort."

AFTER ACTION REPORT  
Atropia Training Exercise  
October 20 – November 2, 2022

USAID Representative – Michael Maxey

RTU -----

Topic: Displaced Civilians (DC) Events.

Discussion: RTU had a good plan for handling DCs which included a “Welcome Center” with all the facilities and personnel needed to (1) identify refugees and Internally Displaced Persons (IDPs), (2) find CCHF infected individuals, (3) screen for and take temporary possession of weapons, (4) identify and segregate dangerous individuals, (5) review IDs and complete a head count, and (6) turn the DCs over to USAID or the UNHCR. In the training scenario, however, the DCs were not easily found by the RTU designated CAT Team. Consequently, having a comprehensive plan for a fixed center to process DCs is a “best case” scenario but difficult to implement in a battle field environment. Any given CAT Team, or more likely, random frontline units will normally have to address a DC situation with any resources they have on hand.

Positive: RTU developed a good DC plan and had a lead CAT Team ready to implement the plan. When conditions on the battlefield did not allow that plan to be implemented, other CAT Teams took control and did a good condition. On TD 5, CAT Team 1 (CPT Kawasaki) NW of Ujen took control of the situation and (with some initial coaching by the UNHCR Rep.) successfully processed 75 IDPs. On TD 7, 35 IDPs were processed by CAT 2 (CPT Blythe) in Razish. In both cases, the encounter with IDPs was unexpected and the CAT Teams did an admirable job in containing, processing and turning over these DCs to the UNHCR and USAID representatives.

Area for Improvement: Poor communications on TD 1 prevented CAT Team 3 from responding to DCs in Reyalem. An RTU supply convoy was in the area and encountered the DCs but was unprepared to address the situation. At one point, a CA vehicle came by but did not stop. DCs began wandering away with local and international press recording the event. At least one person appeared to have CCHF symptoms. The bad press and potential spread of CCHF into Gorgas could have had a negative impact on RTU operations in its engagement with civilian populations as the battle continued.

Recommendations:

- RTU should prepare every unit to execute the basic steps in managing a DC event with a focus on containment, processing and holding for turnover to UNHCR or USAID.
- Cards should be given to every soldier in the RTU with basic instructions on how to handle a DC event.<sup>1</sup> These cards should contain contact information for UNHCR and USAID.

---

<sup>1</sup> Basic Processing Instructions: (1) contain DCs in a building or improvised holding area; (2) male and female soldiers should check IDs of each individual based on gender and write down their names; (3) while checking IDs, screening should be done for weapons (if they have one, it must be surrendered and the person given a receipt), persons infected with CCHF, and dangerous individuals; (4) after screening individuals should be segregated and contained until processing is completed; and (5) a cross check should be made of IDs with a head count of individuals and the DCs along with names of individuals should be turned over to the UNHCR or USAID.

Topic: Initial Essential Services Assessments.

Discussion: On TD 2, CAT Team 3 (CPT Tribble) did an outstanding job in executing an initial assessment of essential services needs in Dezashah. This was the first Atropia city retaken by the RTU from the Donovians and, as such, there was a tremendous amount of symbolism in having the RTU and the USG team respond quickly to civilian needs. The RTU, through CMOC (CPT Richardson) set up excellent communication channels with Division and USAID as well as with All Hands Atropia. Once the assessment was completed it was quickly transmitted and approved.

Positive: Having a completed assessment is only effective if it can be communicated through the CMOC to Division and be approved so that USAID can request All Hands Atropia to disburse the needed humanitarian assistance (HA). The RTU was able to do this for assessments in Dezashah, Ujen and Razish – both CPT Tribble (CAT Team 3) and CPT Blythe (CAT Team 2) did outstanding work as did CPT Richardson (CMOC) in transmitting and gaining approval for HA drops. In the case of Dezashah, USAID learned that the timely arrival of HA prevented a potential protest – this was a significant accomplishment in that the bad press generated by a civilian protest early in the battle could have had negative impact as the RTU moved forward into other civilian areas.

Area for Improvement: While the assessments were adequate for action by USAID, improvements could be made in the format. During initial discussions between the RTU and USAID on essential services, it would be good to agree on a specific format.

Recommendation: USAID develop a one-page format for essential services needs assessments and share with CAT Teams as part of the initial meeting on Essential Services with the RTU on RSOI 3.

NTC -----

Topic: USAID and UNHCR Roles

Discussion: USAID and the UN High Commission on Refugees (UNHCR) have distinctive roles and the training scenario clearly defined that the UNHCR was focused on DCs and how they should be managed and processed. The USAID Rep. focused on supporting the execution of initial essential services needs assessments and the delivery of humanitarian assistance. In responding to DC events, the UNHCR and USAID Reps were allowed sufficient access to the training area in order to interact with the RTU as it managed these events. However, the RTU made four requests for the USAID Rep. to support the execution of assessments and none were approved. While USAID provided virtual support with information, schematics and feedback to the RTU, it would have been more effective to have interacted directly with the CAT Teams in the field on at least one or more occasions.

Recommendation: Allow the USAID Rep. to go to the field to support the RTU in executing one or more of the essential services needs assessments. This would provide training support to the CAT Teams that is congruent with the role USAID has performed in Post Conflict Stabilization events across the Middle East.

Daily Activity Report  
Michael Maxey  
October 20, 2019

**Rotational Training Unit (RTU) Orientation** - Met with Subject Matter Experts (SME) team for briefing on training scenario and discussion of required changes in training scenario script. Focus was on how to present and discuss with RTU the need for different support actions for refugee and internally displaced persons (IDPs). Situation is complicated due to limited access to training area. Program Manager provided guidance and assigned duties for script edits and proposed interaction with RTU.

**Thread Brief** – Reviewed thread brief with team and discussed training scenario. There was general agreement on need to provide more documentation to better support RTU training objectives. Some errors regarding SME team were noted (see pp. 25-26 of thread brief). Overall scenario is understood but more information on exactly what the RTU expects to receive from Inter-Agency support team would be helpful.

**Refugees vs IDPs** – There is a need to clarify refugees versus IDPs -- p. 17 of the thread brief indicates that Atropian IDPs are crossing the border near Dezashah into Gorgas on training day one. It should be noted that once they cross the border and are designated “refugees” they could be subject to different international agreement conditions than IDPs. UNHCR Subject Matter Expert is editing the script for the refugee event on the first day of training to help RTU understand the situation they face with these displaced persons becoming refugees.

**Preparation for Training** – Equipment was issued (box phones) and orientation provided on transportation into the training area (the “box”) in order to support RTU. Vehicle assignments were made and updates provided regarding safety training. Office coverage schedule shared with team and standard operating procedures agreed upon for the duration of the training program.



Daily Activity Report  
Michael Maxey  
October 21, 2019

Non-Lethal RSOI Thread Brief – Attended briefing on scenario and review of Thread with OC staff. Issues were clarified regarding refugees and IDPs. The issue on page 17 of Thread Brief was clarified that Atropian IDPs are crossing the border near Dezashah into Gorgas on TD1 and when they do, they become “refugees.” It was noted that of the 40 dislocated civilians coming into Dezashah, 50% will be refugees and 50% will be IDPs.

Scripts – The final version of the script for NGO Introduction and Displaced Civilians Working Group Meeting needed to be finalized. I took edited version of script, put in final, and forwarded to Program Manager and Team Leader. Later printed 6 copies of Political/Military Meeting script and Displaced Civilians script for team

SOF Meeting with Inter-Agency Team – Participated in meeting with SOF command and staff to discuss situation in Atropia and the Ambassador’s priorities as the U.S. military prepares to move forward on Donovanian forces. Deputy Chief of Mission (DCM) Scott McGehee started the meeting by asking for an assessment of the military situation and highest priority objectives. CDR Jon Stewart gave an overview of the SFG priorities in the near term and a description of how the Inter-Agency Team could be supportive. See attached MemCon.



DCM Discusses Strategy with CDR Stewart B/2/7/SFG (A)

Memorandum of Conversation  
Inter-Agency Team Meeting with B/2/7/SFG Command  
October 21, 2019

Inter-Agency Team met with SOF command to discuss situation in Atropia and the Ambassador's priorities as the U.S. military prepares to move forward on Donovian forces. Deputy Chief of Mission (DCM) Scott McGehee started the meeting by asking for an assessment of the military situation and highest priority objectives. CDR Jon Stewart gave an overview of the SFG priorities in the near term and a description of how the Inter-Agency Team could be supportive.

Key Take Aways:

1. Consular Officer/PDO John Tolly confirmed that to the Embassy's knowledge no American citizens remain in Atropia. There should not be a need for a Non-Combatant Evacuation Operation (NEO) or issues regarding American citizens in the battle space.
2. Atropian Government priorities will focus on clearing and securing of Erdabil Province followed by provision of humanitarian assistance. DCM McGehee mentioned the mix of displaced civilians with both refugees (person who have crossed an international border seeking refuge) and Internally Displaced Person (IDPs – citizens who have been dislocated in their own country) and to be careful in how they are managed.
3. UN HCR Rep. Tim Ecklund highlighted the need identify and process dislocated civilians (whether refugees or IDPs) in a way that protects their rights under international agreements. USAID Rep. cited the need for essential services to be restored as soon as possible once U.S. military enters, clears and secures Atropian territory.
4. DCM McGehee discussed the need to engage with ethnic Lezgin and Bilasuvar leaders and offered to provide support while cautioning the need for the Embassy not to engage in anything related to the PAL or BFB. Regional Affairs Officer Philip Perez cited the need to understand the nuances of ethnic militia groups and offered to provide a side brief.
5. UN HCR Rep. advised the SOF staff of two upcoming meetings that would be important for them to participate in – (1) Displaced Civilians Working Group Meeting to be held on Tuesday, October 22<sup>nd</sup> at 14:00 – 15:00 in Building 9011 RUBA; and (2) Essential Services Meeting on Wednesday, October 23<sup>rd</sup> at 13:00 – 14:00 in Building 9011 RUBA.
6. DCM invited CDR Stewart to attend Political/Military Meeting with COL Ralph Overland, Provincial Governor Moheidin and Provincial Police Chief Khosky scheduled for Tuesday, October 22<sup>nd</sup> at 13:00 – 14:00 in Building 9011 RUBA. DATT Samuel Stauffer cited the importance of military coordination with civilian authorities.

The meeting concluded with an agreement to coordinate efforts and to keep lines of communication open especially concerning dislocated civilian actions, humanitarian assistance, assessments for provision of essential service, social messaging and engagement with Atropian and ethnic leaders.

Inter-Agency Team Meeting with B/2/7/SFG



L-R: Inter-Agency Team - John Tolly, Public Affairs/Consular Officer; Scott McGehee, Deputy Chief of Mission; Michael Maxey, USAID Representative; COL Samuel Stouffer, Defense Attaché; Philip Perez, Regional Affairs Officer. B/2/7SFG – Ben Johanson; Javier Echols; CDR Jonathan Stewart; CW3 Marcus Montez; William Choate.

Meeting Participant Contact Information

<u>NAME</u>	<u>EMAIL</u>	<u>TELEPHONE</u>
Michael Maxey	michael@maxey.info	703-888-9143
CW3 Montez Marcus	marcus.montez@socom.mil	910-988-3333
Jon Stewart	JONATHAN.D.STEWART.MIL@SOCOM.MIL	931-933-1495
Javier Echols	javier.echols@socom.mil	910 580 1380
William Choate	william.choate@socom.mil	440 813 6275
SAM STOUFFER	SAMKSTOUFFER@gmail.com	717 385 1600
Tim Ecklund	Timothy A. Ecklund@gmail.com	661-993-7137
Scott McGehee	smmcgehee@aol.com	619-451-6597
<del>HEADQUARTERS</del> Philip Perez	Perez.philip@hotmail.com	202-374-9382
John Tolly	hthetollylana@yahoo.com	480-849-4440
Ben Johanson	benjamin.e.johanson.mil@socom.mil	307 369 3784





# ARSOF TF 7220

MAJ Jon Stewart  
CDR, B/2/7SFG (A)

## Overview

- Disrupt Donovanian forces and surrogates to enable CJTF-A to defeat Donovanian forces and reestablish the Atropian international border.
- Conduct operations by, with and through partner forces.
- Build shared understanding and generate options to create dilemmas for the enemy.

## Alignment

- ENHANCED PEACE AND SECURITY IN THE REGION
  - 1.1: Secure U.S. interests in the Caucasus Region
- SUSTAINED, DIVERSIFIED ECONOMIC GROWTH
  - 3.1: Facilitate the development, improvement, and protection of Atropia's hydrocarbons-related infrastructure

## Capabilities

- **Personnel:** 98 Personnel
  - 2x SFODAs
  - 1x CA Team
  - 1x PSYOP Team
- **Civil Engagement**
- **Human Network Analysis**
- **Influence Selected Populations**

## Organization

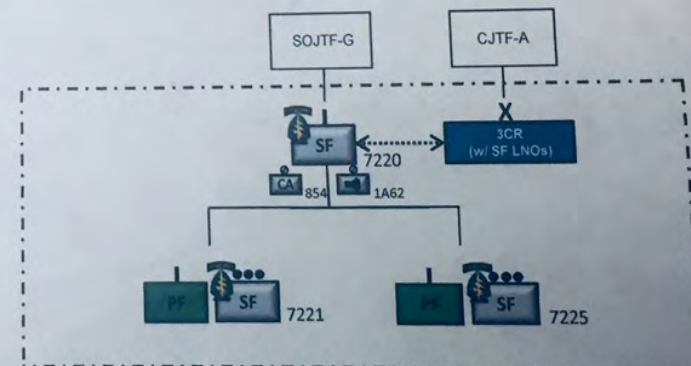

Unclassified//FOUO

Daily Activity Report  
Michael Maxey  
October 22, 2019

USG/BCT Intro Meeting – Inter-Agency Team met with 3<sup>rd</sup> Cavalry Regiment Commander COL Overland to brief on US Embassy priorities, discuss capabilities and determine how best to coordinate efforts as the US military forces Donovanian occupation army out of Atropia. Key points were made by DCM Scott McGehee regarding the Ambassador’s priorities, COL Overland provided his assessment of the situation and highlighted his intent. Humanitarian assistance efforts were discussed and key points made by USAID Rep. See attached MemCon for details of the meeting and information on the participants.

Political/Military Meeting – This was a meeting between Atropian government officials, COL Overland and the Inter-Agency. COL Overland clearly stated to Gov. Moheidin that his intent was to liberate Atropia from Donovanian as soon as possible. Gov. Moheidin thanked him and went on to list his primary concerns (1) beware of BFB and consider them to be the same as Donovanian forces, (2) understand that the Donovanians and BFB have a strong propaganda campaign capability and (3) please meet with ethnic leaders but don’t promise them anything from the Government of Atropia. COL Khosky stated that he does not have police officers in Atropia and even after areas are cleared and secured it will be difficult to provide police. He noted that it is important to know when areas are secured and he asked who in the 3<sup>rd</sup> Cavalry Regiment.

Dislocated Civilians WG #1 – UN HCR rep led a meeting with Gov. Moheidin and staff from the 3<sup>rd</sup> Cavalry Regiment on how to handle displaced civilians. Procedures for managing refugees and IDPS was discussed. All Hands Atropia provided a summary of their services and humanitarian assistance. USAID Rep. mentioned the difference between immediate humanitarian assistance (which AHA can provide literally on the spot) and the essential services assistance which AHA can only provide after an assessment is completed, submitted to Division and approved.

Memorandum of Conversation  
Inter-Agency Team Meeting with COL Overland, 3rd Cavalry Regiment and Staff  
October 22, 2019

DCM Scott McGehee started the meeting by explaining that he wanted to convey Ambassador Barber's concerns and get better insight on the military situation and the needs of the 3<sup>rd</sup> Cavalry Regiment in terms of support with humanitarian assistance, restoration of essential services and supporting local governance in areas of Atropia that are cleared of Donovanian forces. COL Overland stated that his intent was to restore internationally recognized borders, protect displaced civilians and assist the Atropian government in restoring security. DCM McGehee stated that (1) no US citizens are in Atropia and therefore no NEO is planned, (2) ethnic disparities and rivalries are a serious issue and need to be carefully addressed, (3) very active social media and disinformation campaigns could require strong propaganda countermeasures, and (4) rapid restoration of security in cleared areas along with humanitarian assistance to the local populace should be a priority.



USAID Rep. highlighted five points: (1) There are reports of significant numbers of Displaced Civilians (DC) which may include both refugees and IDPs – these civilians have to be processed and classified as either refugees or IDPs, as well as being screened for weapons and signs of Crimean-Congo Hemorrhagic Fever. A DC plan must be developed by the RTU. (2) UN HCR will support efforts to assist civilians and provide transportation to from collection points to either refugee camps or IDP centers – the military will provide secure transportation routes. (3) All Hands Atropia (AHA) will provide humanitarian assistance to civilians (either refugees or IDPs) immediately (no assessment needed) and also provide essential services support after assessment of needs is presented to Division and approved. (4) Once a town is cleared and secured, USAID can assist CA teams in developing essential services needs assessments. When Division receives and approves an assessment, it will communicate with the Inter-Agency Team and USAID will be authorized to have AHA release the needed supplies for essential services. (5) USAID will support the design and implementation of post conflict stabilization activities after security is restored and civilian personnel are allowed to operate in Atropia. It is anticipated that projects suspended due to the Donovanian invasion can be restarted once hostilities have ceased.



The Inter-Agency Team is comprised of DCM Scott McGehee; Consular/Public Affairs Officer John Tolly, Public Affairs/Consular Officer; USAID Rep. Michael Maxey, Defense Attaché COL Samuel Stouffer. The UN HCR Rep. is Tim Ecklund. The contact information for the Inter-Agency Team is provided below.

DCM Scott McGehee – [smmcgehee@aol.com](mailto:smmcgehee@aol.com) – Tel. 619-451-6597 – Box Phone – 11282

Consular/PDO John Tolly – [hthetollylama@yahoo.com](mailto:hthetollylama@yahoo.com) – Tel. 480-849-9440 – Box Phone – 18468

DATT COL Sam Stouffer – [samkstouffer@gmail.com](mailto:samkstouffer@gmail.com) – Tel. 717-385-1600 – Box Phone – 18453

USAID Rep. Michael Maxey – [michael@maxey.info](mailto:michael@maxey.info) – Tel. 703-888-9143 – Box Phone – 12028

UN HCR Rep. Tim Ecklund – [timothyaecklund@gmail.com](mailto:timothyaecklund@gmail.com) – Tel. 661-993-7137 – Box Phone - 14435

The contact information of the meeting participants is provided on the next page.

<u>NAME</u>	<u>Email</u>	<u>Telephone</u>
Michael Maxey OSAD Tel Aviv, Embassy	michael@maxey.info	703-888-9143
CPT Marion Nederhoed 3CR PAO	marion.j.nederhoed.mil@ mail.mil	231.920.0223
MAJ Nick Craig 3CR CHOPS and Aviation Officer (worked w/ USAID in <sup>Israel &amp;</sup> Jordan)	nicholas.l-craig.mil@mail.mil	931-302-5050
CPT HEIDI CARIGNAN 3CR CIVIL AFFAIRS PLANNER	heidi.l.carignan.mil@mail.mil	254-338-6426
MAJ Sean Miller, Regt 53	sean.n.miller2.mil@mail.mil	254-415-5608
MAJ Simon Welte, RXO	simon.p.welte.mil@mail.mil	(666) 407-0141
CPT KRIS RICHARDSON B/445 CABN CDR	KRISTOFER.B.RICHARDSON.MIL	(831) 915 5196
CPT WADE JOINER	WADE.M.JOINER@mail.MIL	618 419 4137
Jonathon Burnett Regimental HUMINT Tech	jonathon.g.burnett.mil@mil.mil	(270)-752-5100 DSN: 760-380-2473
CPT Eric Paul Regimental Provost Marshal	eric.a.paul4.mil@mail.mil	Box phone: 15388 415-603-1783
MAJ Greg Isham Regimental Judge Advocate	gregory.t.isham.mil@mail.mil	254-423-7567
MAJ George Coss Regimental Fire Support Officer	george.l.coss.mil@mail.mil	260-447-5555
COX (Ret) Samuel K. Stouffer	SAMKSTOFFER@GMAIL.COM	717 395 1600

Daily Activity Report  
Michael Maxey, USAID  
October 23, 2019

USAID Brief to SOF CA – Briefed the Special Operations Force (SOF) Civil Affairs (CA) Team at 10:30 on USAID coordination with local Non-Governmental Organizations (NGOs) and International Governmental Organizations (IGOs). Samira Malfouf participated in the meeting with CPT Choate and other SOF CA staff. Discussion focused on USAID coordination with NGOs and IGOs. We discussed (1) attached summary of USAID projects, (2) AHA Executive Director discussed CCHF and symptoms, (3) we reviewed the immediate HA support for DC versus HA to cover essential services needs based on an approved assessment and (4) SOF discussed their input into plan for handling DC.

Essential Services Meeting - Chaired meeting with Rotational Training Unit (RTU), Gov. Moheidin and staff, and UN HCR Rep. on essential services. It was a good meeting and the RTU appeared to understand the situation they will face in Atropia and the need to move quickly to draft and submit essential services assessment quickly to Division. See attached meeting agenda and Talking Points along with contact information of participants.

Dislocated Civilians Meeting – Attended DC Working Group #2. Many of the same staff were present from the Essential Services meeting. The RTU presented an excellent Displaced Civilians (DC) management plan. See attached copy. Gov. Moheidin participated in the meeting and provided good information on cultural aspects of DC management. UN HCR and AHA Executive Director highlighted the need for flexibility and cultural sensitivity. RTU appeared to be well briefed and is proactive in preparing brigade for DC events. LTC Ed Gavin participated in the meeting and discussed the security his squadron will provide for rear area security.

## USAID Atropia Brief to SOF CA

Atropia gained its independence in 1983. USAID has provided over \$350 million since 1991 with a focus on two sectors: (1) Supporting the economic growth of non-oil sector; and (2) strengthening democracy and governance. Atropia has provided \$20 million in matching funds to achieve economic reform goals. Current portfolio is funded at \$81.05 million in three sectors: Democracy and Governance (\$39.35 million), Economic Growth (\$33.90 million) and Health (\$7.0 million).

Democracy & Governance – \$39.35 million - USAID works with public sector partners and civil society to strengthen democratic practices and standards of accountability, encourage citizen participation, foster government transparency, and efforts to empower women and combat human trafficking.

Elections - \$5.5 million – IFES

Access to Legal & Policy Information - \$1.2 million – NCSC

Anti-Corruption Project - \$800,000 – Council of Europe

Media Advancement - \$5.75 million – IREX

Independent Media - \$2.5 million – Internews

Community Development - \$11.45 million – CHF International

Atropian Community Security - \$2.7 million – Chemonics

Erdabil Stabilization - \$9.45 million - DAI

Economic Growth – \$33.9 million - USAID supports a business and investment friendly environment and increased trade through economic integration and trade with Europe. Major reductions have occurred in poverty due to opening of gas pipeline Baku-Tbilisi-Ceyhan in May 2005. Non-energy sector lags behind. Focus is on diversification of the economy with a focus on agriculture sector. Support is provided to improve banking efficiency and accountability with focus on promoting market-based financial services to small and medium enterprises. Activities also include work force development, regional trade promotion, etc. This area is also where education support activities are taking place.

Atropia Economic Dev. Project - \$1.5 million – Citizens Dev. Corps

Treasury Information - \$7.3 million – Carana Corporation

Energy Assistance - \$5.5 million – PA Government Services

Municipal Rehabilitation - \$4.2 million – AECOM

Agriculture Projects- \$11.9 million – Farmer to Farmer (\$500,000); Participatory Ag (\$2.4 million); Rural Credit (\$5.9 million); Ag Input (\$3.1 million)

School Economics Education - \$3.5 million – Junior Achievement

Health – \$7.8 million - Support for activities in three areas – (1) TB control, (2) child healthcare and (3) women and child nutrition. USAID programs also focus on strengthening the capacity of the Ministry of Health to advance health reform initiatives, improving the use of health resources and improving the quality of health services.

Child Survival - \$1.3 million – Mercy Corps;

Primary Healthcare - \$5 million – Intl. Medical Corps;

Reg. Water Project - \$1.5 million – PA Consulting

Talking Points  
Essential Services Assessments  
Services Restoration and Security Handover Planning  
October 23, 2019

I want to welcome everyone here today to this important meeting regarding the need for rapid needs assessments once areas of Atropia are cleared and secured.

Your Excellency, Gov. Moheidin with your permission I would like to start the meeting with introductions followed by some remarks on the importance of essential services in stability operations. I will then ask if you would provide us with an overall update of the situation and your estimation of the capability of the Government of Atropia to restore essential services and any other issues you wish to highlight.

So, I want to start by passing out an agenda and highlighting what we want to accomplish in this meeting. Basically, we want to get an update from Gov. Moheidin and COL Khosky on capabilities of the Atropian government to provide essential services and to restore local security in cleared areas of the Erdabil province. We also want to discuss public messaging, review USAID capabilities and limitations and receive comments from the UN HCR on US military obligation under international agreements.

Talk about the importance of essential services ...

Now Your Excellency, Gov. Moheidin, if you could please provide an update and an estimation of the capability of the GoA to restore essential services ...

RTU responds to Gov. Moheidin's update and questions ...

COL. Khosky provides update and comments ....

PDO will discuss public messaging ...

USAID will discuss Needs Assessments – two types – (1) immediate (food, shelter, water & medical), and (2) post conflict stabilization which will include “confidence restoring” high visibility projects but this requires security. Current State Department guidance indicates that USAID personnel will only enter an area after RTU has moved forward.

PDO – Messaging re liberated towns

UN HCR – comments

Are there any more questions? Close the meeting.



# AGENDA

## Essential Services Meeting October 23, 2019

1. Introductions
2. Overview of the Importance of Essential Services
3. Update from Gov. Moheidin
4. Update from Erdabil Police Chief – COL Khosky
5. US Embassy PDO - Discussion of Public Messaging
6. Discussion on Post Conflict Needs Assessments
7. UN HCR - Obligations of US Military re UNSC resolution.
8. Questions and Answers
9. Closing Remarks

## جدول أعمال

اجتماع الخدمات الأساسية  
أكتوبر 2019 23

1. مقدمات
2. نظرة عامة على أهمية الخدمات الأساسية.
3. التحديث من حاكم محي الدين
4. تحديث من قائد شرطة أردبيل - العقيد خوسكي
5. مناقشة المراسلة العامة - PDO السفارة الأمريكية
6. مناقشة حول تقييم الاحتياجات بعد انتهاء النزاع
7. مجلس حقوق الإنسان التابع للأمم المتحدة - التزامات الجيش الأمريكي.  
بقرار مجلس الأمن
8. أسئلة وأجوبة
9. ملاحظات ختامية

Participants in the Essential Services Meeting  
10/23/2019

Name	Organization	Email	Tel. Number/Box Phone
Michael Maxey Maj Quee	USAID Ambassador ACAT	michael@maxey.info	703-888-9143 Box Phone - 12028 251-490-8707
SSG Austin	RHHT, 3d CR	Nathan.J.austin.mil@mail.mil	912-980-3257
CPT Richardson	BHUS CA ICMCI	KRISTOFER.B.RICHARDSON.MIL	837 915 5014
CPT MULHOLLAND, M.	BHUS CA	MATTHEW.J.MULHOLLAND.MIL	925-548-2003
CPT Tribble	BHUS CA	Kristina.m.tribble.mil	616-916-8228
CPT Gribble	3CR CAT 3 - REAR UNIT	william.s.gribble.mil@mail.mil	N/A -
COL Khoyzki	PCOP		1-5348
John Tolly	PDD/Consular Officer US EMB Baku	hnttollylana@ yahoo.com	480-849-9440
LTC ED GAVIN REAR AREA SECURITY	3d CR, Engineer Squadron Commander	edward.p.gavin2.mil@mail.mil	254-423-4799
RAED FROUKH	Linguist	FROUKH@COMCAST.NET	267-549-2101

---

# DC Welcome Center Plan



B Company 445<sup>th</sup> Civil Affairs Battalion—

---

---

**INTENT:** DC Welcome centers are to be quickly setup for short periods of time. Host nation personnel will receive IDPs, provide security and assist in screening IDPs. Civil Affairs (CA) units and other US military/ coalition forces will provide the following services within the Welcome centers: security, screening, and documenting IDPs, as well as submitting supply requests, and transportation requests (as necessary) for all IDPs.

**TIME:** Civil Affairs units and Unified Action Partners are capable of establishing a DC Welcome center within 4 hours of notification of trigger, and are capable of having a Humanitarian Assistance Drop within 24 hours of notification of trigger.

## Objectives

- Protect civilians from combat operations
  - Prevent uncontrolled out breaks of disease among DC's which could also threaten the health of military forces
  - Relieve human suffering
  - Encourage people to remain in their homes or if necessary move to DC welcome center for transportation to the DC camp in ~~Vella~~
-

## DC WELCOME CENTER

---

### Requirements for one welcome center

**Who:** B Co 445<sup>th</sup> CA, RES, JAG, TPT, MP Company, translators,

B Co 445<sup>th</sup> CA BN

- One CA Team (4 x pax)

\*

**RES**

-one squad sized element (8-12 pax)

-6 female soldiers

-4 medics

**TBD MP Co**

-MPs 1 squad sized element (8-12 pax)

\*Each welcome should have at least 6 or more female soldiers to assist with security and medical screenings of female IDPs. The female soldiers will be provided by any of the units represented.

---

## DC WELCOME CENTER

---

### **What:**

T1: Provide security

Unit: RES

P1: Provide inner cordon

T2: Conduct Screening utilizing Tab 2 (Screening Questionnaire) as well as screening for contagious/ infectious diseases

Unit: CA, Medic,

P2: To mitigate the DC's fears, explain what you need and why

T3: Request Humanitarian Aid Drop (water and if necessary medical)

P3: Unit: CA unit will reach out to NGO (All Hands Atropia) and IGOs directly

T4: If necessary request transportation for IDP movement to DC Camp in Vettia province.

Unit: CA unit will contact CMOC and/ or reach out to NGO and IGOs directly

- It is recommended that we encourage the populace to remain in their homes
  - CA teams will request IDP transportation to a DC Camp in ~~Vettia~~
  - Transportation will be provided by the Atropian Government or UNHCR
  - Child Soldiers identified and turned into UNICEF
  - WHO will be contacted to transport sick IDPs
-

## DC WELCOME CENTER

**When:** on order or when civilians are reported to be moving into the battle space from population centers

**Trigger:** Once IDPs are identified

**why:** to protect, local populace, minimize combat interference, understand reason for their flight, and identify and reduce insurgent elements.

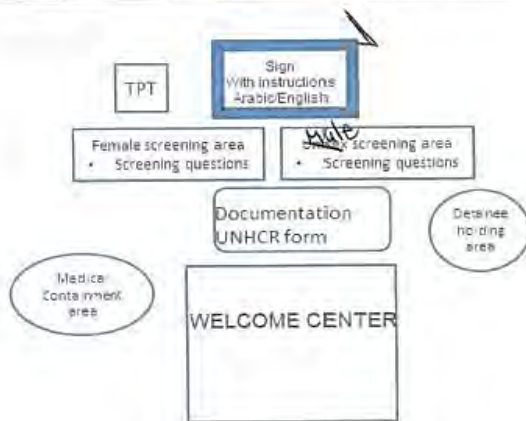

- The welcome center should be kept simple, tarps or camo nets for shade, and water.
- Detainee holding area will be operated by MPs
- The Security screening area should have standoff from the main area.
- Security and medical screening will be conducted
- IDPs will be documented with BATS and HIIDs and will sign in on UNOCHA provided rapid registration form
- Cordon area is to protect those that are in welcome area, but IDP are free to leave
- Atropian Government or UNCHR will provide transportation to DC camp

## Concept of the Operation

### Phase 1: Messaging

- Coordinate and implement "stay-put" policy with host nation leadership to minimize interference and safeguard civilians.

### Phase 2: Identification

- Group of DC are reported in the battle space. CMOG will contact, Atropian Gov. Atropian Police Force, USAID, UNHCR and UNOCHA and appropriate NGOs to inform them of the situation.

### Phase 3: deployment

- CA TMs assigned to Squadrons will contact DCs and direct them off main routes toward the Welcome Center. *- Need to lead them off -*
- Check points may be established by forward elements to direct DC to the welcome center.

### Phase 4: Welcome Center Ops

- Upon arrival at the welcome center there will be a security screening, then register (*name, age, sex, city or residence, contact number, etc.*), followed by a medical screening focusing on CCHF.
- DC may receive medical treatment from U.S. military for life, limb, or eyesight. People believed to have CCHF will be separated from the larger population and will receive separate transport. For unaccompanied children contact UNICEF
- Possible insurgents are transferred to the Host Nation if capable. *- contact ICRC -*
- Enemy combatants are separated and are transported to the regimental detainee collection point *- ICRC*

---

Tab 1 Displaced Personnel Screening Questions

1. What is your name?
  2. Who is your next of kin?
  3. What village/city are you from?
  4. Why did you leave your home?
  5. What was/is your occupation?
  6. Who is the leader of the group? (if multiple personnel)
  7. Where are you traveling? By what means?
  8. What route are you taking/ have you been taking?
  9. Have you encountered any obstacles or hostile activity?
  10. Are you being pursued?
  11. Are you sick/injured or do you require medical aid?
  12. Does your group have enough food/ water/ supplies?
  13. Have you been in contact with any U.S. or Atropian forces recently? If so, where and when?
  14. Have you been in contact with any Donovanian and/ or BFB forces recently? If so, where, when, and what was the encounter? How many were there?
  15. Have you been in contact with cartel members recently? If so, where, when, and what was the encounter?
  16. Has anyone tried to exploit you?
  17. Do you feel endangered?
  18. Why do you believe our forces are here?
  19. What is our opinion of U.S. presence here?
-

Daily Activity Report  
Michael Maxey  
October 24, 2019

Radio Check & Misc. Actions – At 9 am meeting at Inter-Agency Office, DCM Scott McGehee highlighted the need for good communication when training in the box starts tomorrow. Team checked out the radios and worked on the contacts lists to make sure we have box phone numbers for key staff. Team Leader requested information from Raytheon on training in radio use for team members. Tentatively team is scheduling for radio training for tomorrow morning.

Roll Out – As other IA Team members took on their assigned roles and actions for the day. I was able to observe the roll out of some elements of what appeared to be the 3<sup>rd</sup> Cavalry Regiment (RTU). Apparently, some equipment and staff are still arriving but it looks like the roll out has started. I touched base with the Executive Director of All Hands Atropia (AHA) and mentioned the roll out and asked that she share information on any actions from the field. This was a follow up to the SOF CA meeting that I had yesterday with AHA CPT Choate. See photos below.



Roll Out of military assets.





Meeting – AHA, USAID with SOF CA



All Hands Atropia Executive Director Samira Malouff

Daily Activity Report  
Michael Maxey  
October 25, 2019

OC Chat Groups – Participated with IA Team listening in on the OC Chat group (Radio channel 136 at 14:30). Displaced Civilians (DC) Plan review was good. Need more clarity on a press release from yesterday that reported the death of civilian – need to make clear RTU was not responsible. Media events were good. Today’s protest was well managed. Next 24 hours we have the DCs (there is high possibility they may cross the border before they are encountered at which point they would all be refugees). If refugees are encountered, the RTU would need to contact the UN and International Red Cross -- this would probably happen near Reyalem. It is uncertain how the Atropians would be entering Gorgas under the Day 1 Training Center. It appears that Reyalem which is Gorgas may be a encounter point for DCs.

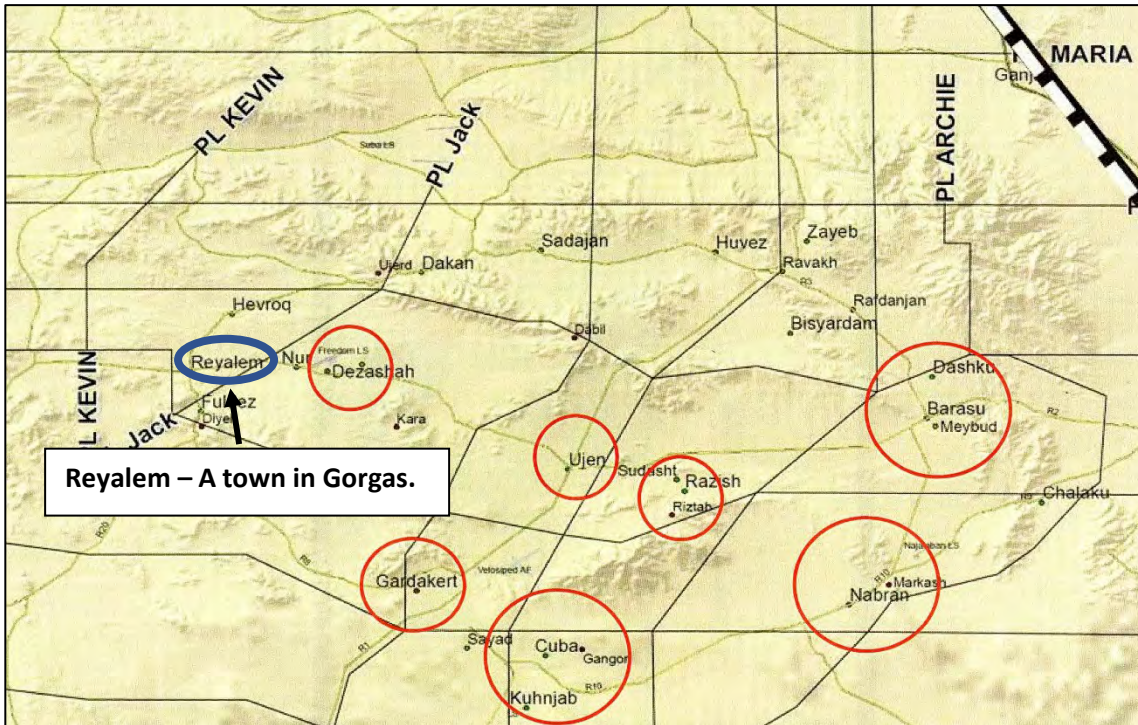

Daily Activity Report  
Michael Maxey  
October 26, 2019

Inter-Agency Team met at IA office and UN HCR and USAID Reps departed for destination near Reyalem (see timeline below).

Indications were that a Displaced Civilians (DC) movement would take place from west of Reyalem moving from direction of Ugen/Dezashah toward Reyalem. Since Reyalem is in Gorgas, all of the DCs would be classified as refugees.

Three issues the IA team discussed prior to taking up a position near Reyalem were: (1) IA team is uncertain who will encounter DCs on the road coming to Reyalem; (2) OC chatter on Radio 136 indicated CA unit responsible may not have requested interpreters; and (3) CAT Team 3 which was identified as the lead team for DCs (CAT Team 3) during initial briefs with RTU was not available but was assigned another duty.<sup>1</sup>

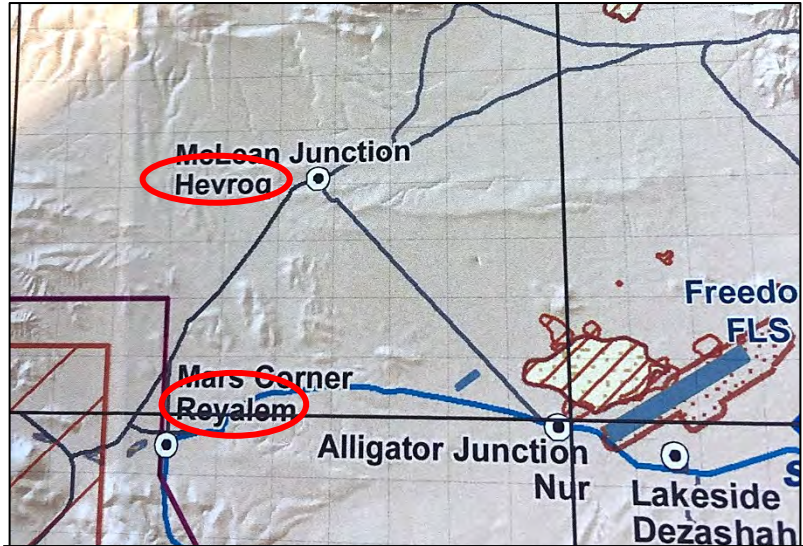

**At approximately 9:30, UN HCR and USAID Reps arrived in Reyalem. Apparently, RTU communications were not working but through radio chatter and after-action discussion with OC, it was determined that CAT Team 3 was in Hevroq doing an Essential Services Assessment during DC event in Reyalem. DCs arrived in Reyalem at around 10:30. No CAT Team was present. DCs left Reyalem and wandered into Gorgas countryside at 12:00. Local and international press were present. Local press informed USAID Rep that at least one of the DCs showed symptoms of CCHF. CA personnel (1 vehicle with 3 soldiers) apparently came by at one point but were unresponsive to the DCs.**

<sup>1</sup> After action discussion with OC SGT Leknes in Reyalem indicated that CAT Team 3 was in Hevroq conducting an assessment when the DCs arrived in Reyalem. After action call with CAT Team 3 leader CPT Tribble indicated that her team did not have functioning communications. According to her, Box Phones were dead in the area of Hevroq. Chatter of Radio 136 indicated that a “sync” had not been done properly and this was affecting all radio communication in the area. It should be noted that Hevroq is approximately 3 miles from Reyalem and both are still in Gorgas. After Action call on Box Phone from CPT Tribble provided an opportunity to inform RTU that DCs has wandered away and were not taken by the UN HCR Rep. Also, allowed an opportunity to inform RTU that at least one of the DCs was infected with CCHF.

## Timeline

8:30 – IA Team Meeting

8:45 – UN HCR and USAID Reps depart for Reyalem area.

9:35 – UN HCR and USAID Reps arrive in Reyalem area.

10:00 – Radio chatter indicated DCs were spotted 5 kms east of Reyalem. No CA team was available to go to the DCs but initial aid was given and injured were treated. RTU advised to redirect DCs to the nearest area for processing. UN HCR and USAID were not sure where that processing center is located.

10:20 – IA Team DCM contacted UN HCR and USAID with information on DC movement (DCM had heard same radio chatter) and confirmed the RTU had encountered DCs.

10:25 – Large convoy of military trucks stopped on the outskirts of Reyalem.

10:32 – All Hands Atropia (AHA) Executive Director Samira Malfouf contacted UN HCR and USAID Reps to inform them that she had been told some element of the RTU had encountered the DCs and provided initial assistance. At this point, the DCs were waiting for the arrival of CA personnel.

10:36 – Radio chatter -- 71 Fox to 71 Bravo??? – “Comms not working – this seems to be a trend.” “There is a civil engagement in Hevroq -- there will be a request for HA based on essential services assessment.” “Can we take control of one of the trucks for a couple of minutes?”

10:42 – UN HCR and USAID Reps saw DCs coming into Reyalem. It was uncertain who was there to receive them. As it turned out, no one was there.

10:51 - The DCs began to harass any RTU vehicles that drove through Reyalem. CA unit still not available to assist DCs.

11:10 – RTU vehicle in vicinity has 3 CA soldiers in it. DCs approach vehicle and try to engage the CA personnel. Local press was observing this. CA staff did not engage the DCs.

11:24 – OC informed AHA (who then communicated with UN HCR and USAID) that DCs would be allowed to disperse into the Gorgas countryside at 12:00 if no CA team arrived prior to that.

12:00 – UN HCR and USAID Reps departed Reyalem heading back to base.

14:40 – CPT Tribble (Box Phone 17557) called USAID Rep and asked what happened to the DCs. USAID Rep explained that they wandered away at 12:00 and that at least one appeared to be infected with CCHF. USAID Rep explained that USAID and UN HCR could assist with Essential Needs Assessment. CPT Tribble indicated CAT Team 3 would be doing an assessment in Nur tomorrow. USAID Rep told CPT Tribble to call on him on his Box Phone number if the CAT Team wanted assistance in doing the assessment.

Reyalem, Erdabil - Atropia

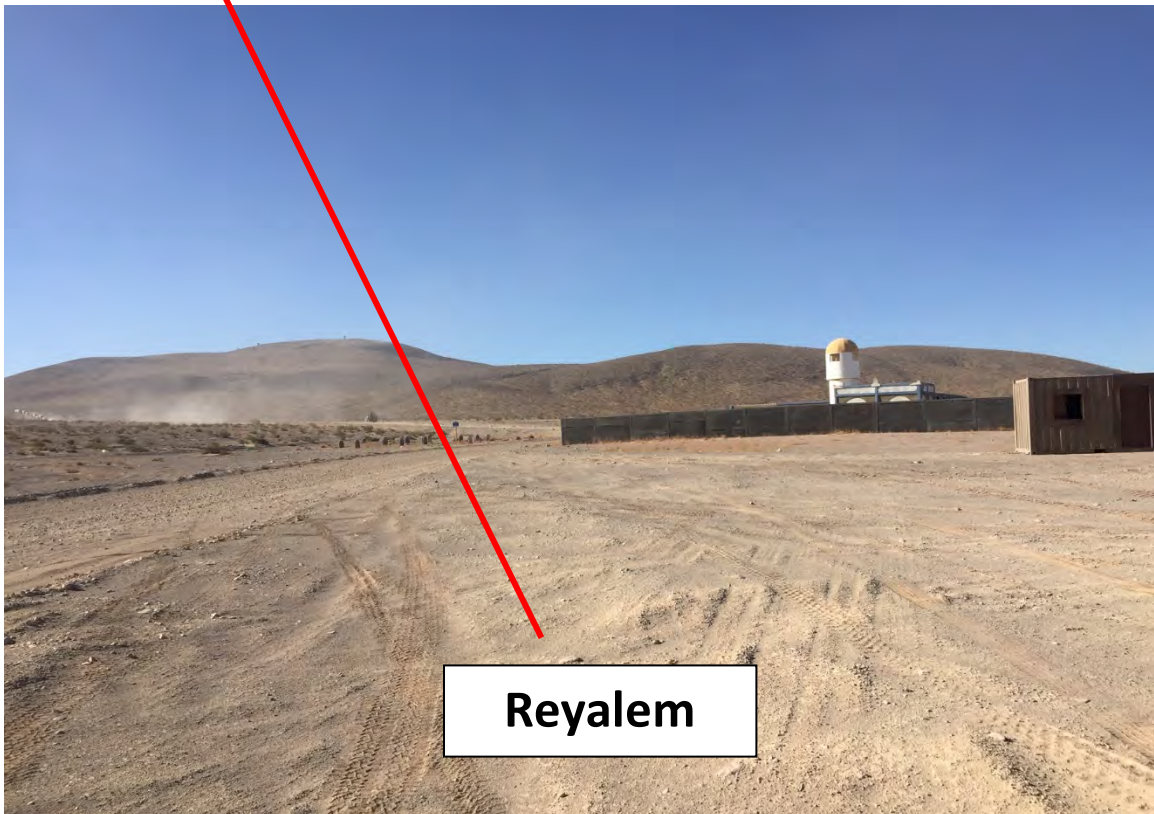
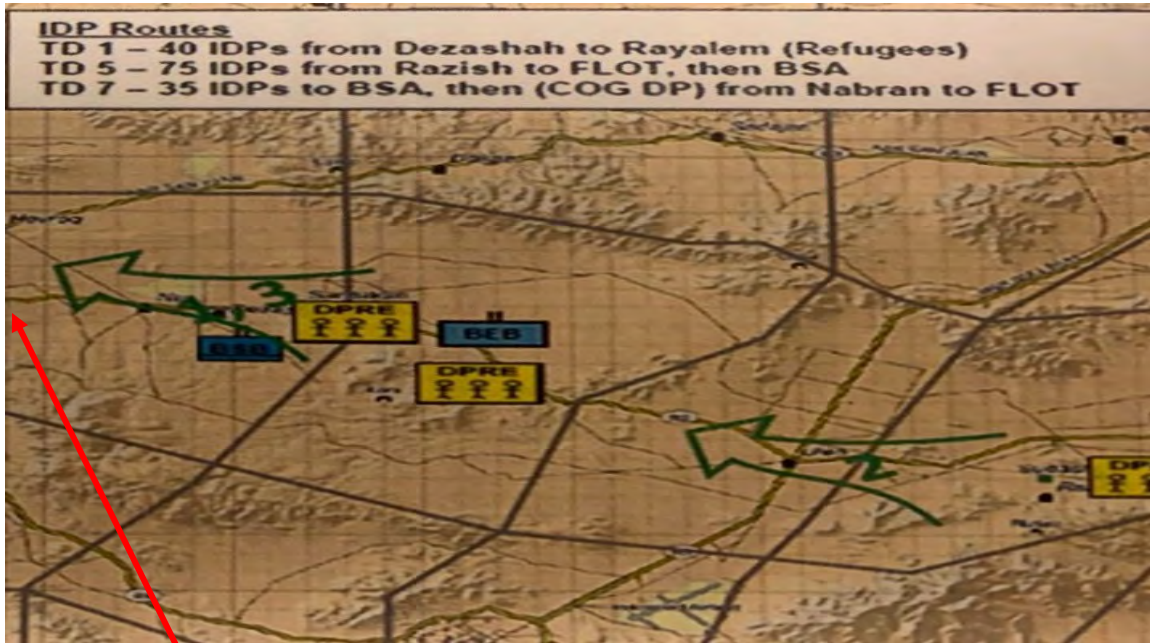

Daily Activities Report  
Michael Maxey  
October 27, 2019

9:00 - Participated in IA Team meeting. Report out by Team Leader on morning intelligence brief. Key points: (1) RTU is past Dezashah; (2) damage to infrastructure reported in Hevroq; (3) OC indicated there would be no humanitarian assistance (HA) drop today (TD 2); (4) IA Team will not pre-position USAID Rep near Dezashah; and (5) meeting will be held today by IA Team with RTU and Ferdowsian.

9:30 – Brief by Program Manager. Update provided on training scenario. Request made to team to review and note any discrepancies in the 20-02 Thread Brief and in the Thread. Discussed ways to improve feedback on training scenarios.

9:50 – Call from CPT Tribble, CAT Team 3 lead. CAT team 3 was on outskirts of Dezashah and would proceed to do Essential Needs Assessment there today. CPT Tribble asked if USAID Rep was available to assist with assessment. USAID Rep informed CAT Team lead that IA Team lead stated that area was too insecure for USAID entry. USAID Rep provided feedback on Essential Needs Assessment that was done the previous day in Hevroq.

10:00 – 12:00 – Monitoring radio traffic on 136 for any news of RTU operations in Erdabil province. Email from S9 to IA Team lead indicated DC movement between Hevroq and Dezashah. Emails from All Hands Atropia (AHA) Executive Director Samira Malfouf indicated that requests may be forthcoming from RTU for HA in cleared areas. USAID Rep communicated AHA Executive Director that USAID involvement to the CMOC (CPT Richardson) that he was available to assist but was not able to enter military operations area today for security reasons. USAID Rep indicated to the CMOC that he needed to have direct line of communication with the CMOC.

13:00 – RTU sent email with Essential Needs Assessment for Dezashah via the CMOC to Division – USAID Rep was copied on email. USAID was informed by Program Manager that Division had approved the assessment. USAID Rep informed AHA to proceed with HA drop as soon as possible. AHA Executive Director Samira Malfouf was standing by and took immediate action to deliver the needed HA by 15:00 today. This was outstanding work by the RTU (**special shout out to CAT Team 3 and CPT Tribble**), Division and AHA. See attached copy of email approval chain.

14:30 - Summarized critical information on towns in area of operation for RTU. USAID annotated a map of Erdabil Province with information urban areas as they were prior to the Donovanian invasion. USAID Rep forwarded this information to CMOC (CPT Richardson) and explained that although USAID was unable for security reasons to be in the area of operations, it was trying to find ways to support the RTU's need to supply needed humanitarian assistance. See attached email copy and map.

15:00 – 15:30 – USAID Rep listened to de-brief by OC team on Radio channel 136. Key points from the de-brief are the following: (1) Since the HA drop was made today in Dezashah, the protest that was planned to take place there will instead take place in Ujen later in the day tomorrow; (2) RTU performance is 100% better today compared to yesterday; (3) RTU media activities have a long way to go (especially social media); (4) TOC is moving; & (5) Lezgin leader will meet with LTC Gavin – time TBD; and (6) RTU needs to focus media on objectives linked to different populations (e.g., Bilasuvar, Lezgin and Atropian).

## Approval Email from USAID to CMOC re Dezashah Essential Needs Assessment

**Michael Maxey** <michael@maxey.info> 5:13 PM (51 minutes ago) ☆ ↶ ⋮

to Kristofer, Angelo, William, Katie, Edward, Heidi, Samira, Tim, Scott ▾

Hi CPT Richardson,

Given that the official communication channel from USAID is through the CMOC, I am advising you that I have been informed that Division has approved the Dezashah Essential Needs Assessment. I have reviewed and concur in this approval.

I am notifying All Hands Atropia Executive Director Samira Malfouf that she is cleared to provide essential services HA as soon as possible to Dezashah. I am also advising our multi-lateral partners (UN HCR).

Normal turn around is 24 hours from approval of assessment to delivery of HA. The process is starting now with the goal of having the HA in Dezashah before 14:00 tomorrow.

Thank you, CPT Carrignan and the CAT Team 3 lead CPT Tribble for quick action on the Essential Needs Assessment. Excellent work!

Michael Maxey  
USAID Rep. - Atropia

[LinkedIn Profile: MMaxey](#)  
Email: [michael@maxey.info](mailto:michael@maxey.info)  
Cell: 703 888-9143  
Box Phone: 12028

## Annotated Map of Erdabil Province with Pre-Invasion Information on Key Urban Areas

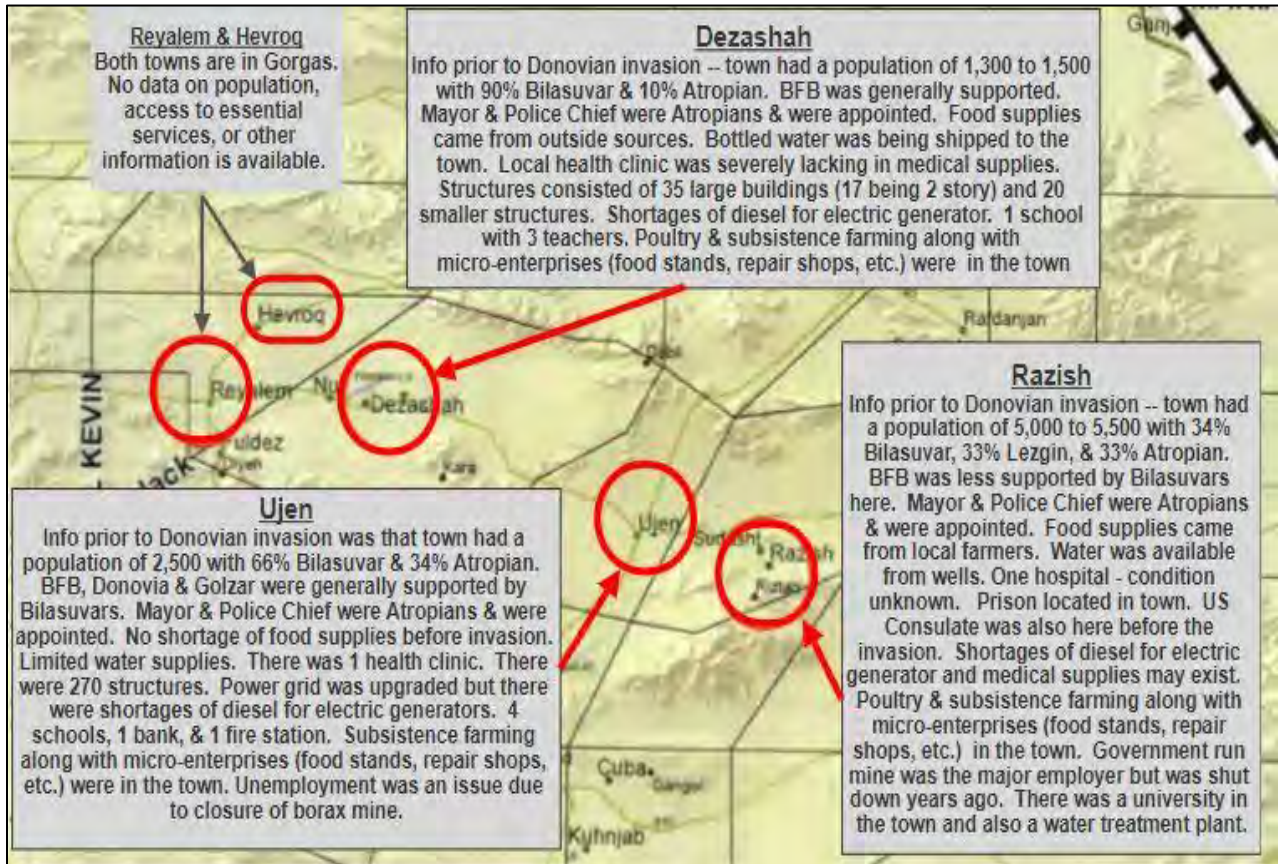

Email – Approval thread for Essential Needs Assessment for Dezashah – TD 2 (10/27/2019)

 **Michael Maxey** <michael@maxey.info>  
to Sam, Scott, Tim, Samira <>  
Sam and Scott <>

CMOE (CPT Richardson) sent email below with Essential Needs Assessment of Dezashah attached to SF (CPT Damignan).

Assessment of Dezashah looks good.

Awaiting word from Division that the Dezashah Essential Needs Assessment is approved.

Michael Maxey

[LinkedIn Profile: MMaxey](#)  
Email: [michael@maxey.info](mailto:michael@maxey.info)  
Cell: 703 888-9143

\*\*\*



 **Sam Abdallah** <sam.abdallah@velin.org>  
to me, Scott, Tim, Samira <>  
Ok that is great

Sent from my iPhone

On Oct 27, 2019, at 1:19 PM, Michael Maxey <michael@maxey.info> wrote:

\*\*\*

<DEZASHAH\_INITIAL\_ASSESSMENT\_27OCT19\_CAT3\_445\_CA\_BN.docx>

 **Sam Abdallah** <sam.abdallah@velin.org>  
to me, Scott, Tim, Samira <>  
This assessment is good enough to proceed with RA. I sent a note to the group on signal. Thank you.

Sent from my iPhone

On Oct 27, 2019, at 1:19 PM, Michael Maxey <michael@maxey.info> wrote:

\*\*\*

<DEZASHAH\_INITIAL\_ASSESSMENT\_27OCT19\_CAT3\_445\_CA\_BN.docx>



## Email Sending Annotated Map to CMOG

Michael Maxey <michael@maxey.info>  
to Kristofer, Scott

5:33 PM (29 minutes ago) ☆ ↶ ⋮

Hi CPT Richardson,

I have been informed that Essential Services HA will arrive in Dezashah via the USAID funded local Non-Governmental Organization (NGO) All Hands Atropia (AHA) by 15:00 today (10/27/2019). Thanks again for the quick response on the Essential Needs Assessment and submission up your chain of command.

I am still uncertain as to when security situation will allow me in the theater of operations but I wanted to share the attached summary I pulled together of key attributes of urban areas in Erdabil Province prior to the Donovan invasion. Note that conditions may have changed dramatically but this was the last information USAID had available prior to the invasion. This may help with your essential services assessments as the RTU moves forward. Again, this information must be updated but at least you will have a baseline of prior conditions.

See below and attached.

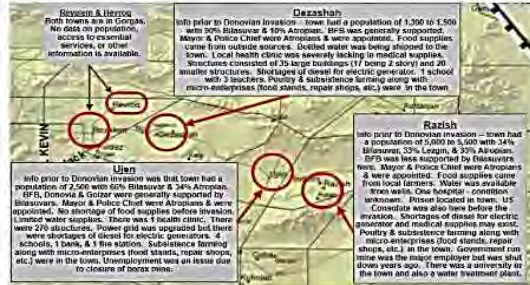

V/R

Daily Activities Report  
Michael Maxey  
October 28, 2019

9:00 - Participated in IA Team meeting. Program Manager informed the team that there would be a Suspension of Battle Engagement (SOBE) today until 17:30. Team reviewed actions required to complete our assignments for this rotation (e.g. After-Action Report, expense reports and Time & Attendance, etc.).

9:45 – IA Team meeting ended. No action is to be initiated by the IA Team until after the end of the SOBE later today.

10:00 – 12:30 – Reviewed Master Copy of the Thread and made comments on activities from RSOI 01 through RSOI 03 (pp. 1 – 20). See attached notes.

13:30 – 16:00 – Started summarizing real life events that have some type of a bearing on RTU training. See overview slide from Foreign Affairs Counter Threat (FACT) Training slides – I will draft a narrative to along with these slides: Focus on (1) Honduras – Attack on USAID Building; (2) Peru Hostage Situation w/actions by Delta Force; (3) Iraq - USAID Rep. in an Embedded Provincial Reconstruction Team; and (4) Yemen - attack on Embassy Sana'a and planned Non-Combatant Evacuation Operation.

Comments on 20-02 Thread  
Michael Maxey  
10/28/2019

This is a review of the Thread commentary from RSOI 01 through TD 03.

RSOI 01 – 0900 – Social Media – 06-08 – p. 1 - BFB Blog post cites the corruption of the Atropian government and its repression of the Bilasuvar people. US invited to “get involved” – “This is an opportunity for the US to get a foothold.” Note: From this narrative on social media, it does not appear that Donovia has invaded Atropia yet.

RSOI 01 – 0900 – Social Media – 06-01 – p. 1 – Several civilian posts from Dezashah, Reyalem, Razish, Ujen and Gardekert are scared the Donovians are going to launch missiles into Erdabil Province. Note: The Donovians already control Erdabil Province – why would they launch missiles into an area they control?

RSOI 01 – 1001 – Social Media – 06-12 – p. 2 – Azaad Yaqub Bazar releases statement regarding the arrival of US forces in Gorgas. Second sentence is about a Donovanian invasion – “He ... speculates that a Donovanian invasion is imminent ...” Note: I am not sure which country would be invaded – Atropian has already been invaded by the Donovians.

RSOI 01 – 1530 US Gov – 04-01 – p. 3 – Overall thread here looks good. USG players include (DoS, USAID, Regional Affairs, DATT, RSO, DOJ, Social Media). Note: We list a variety of SMEs as USG players – might want to edit this to include only the SMEs on the rotation.

RSOI 02 – 1000 – US Gov – 04-02 – p. 6 – Phone call USAID to SOF CA to set up a meeting with the SOF CA for 10:30 on RSOI 03 at SOF RUBA. Note: This is ok – but see subsequent threads on the meeting – it lists two times for the same meeting – see below.

RSOI - 02 1100 - US Gov – 04-03 – p. 6 – Introductory meeting w/BCT CDR. See last two sentences – “DCM should request a daily brief phone call with the BCT CDT. DCM will justify such a daily phone call by stating that He or She would have to update the Ambassador in Baku on a daily basis.” Note: The Ambassador in this rotation would not be in Baku since it is in Atropian territory occupied by Donovia.

RSOI – 02 1500 – Social Media – 06-24 – p. 11 – Donovia Today – “Atropia is in violation of Donovia’s sovereignty and territorial integrity ... we call on Atropia to return control of Vetlia, Erdabil and Hachzi provinces ...” Note: Donovia has invaded and taken control of Atropia, so this text about giving back these provinces does not make sense for this rotation.

RSOI - 03 07-12 – p. 13 – Media INN – “... a Donovanian invasion is imminent ...” Note: Donovia has already invaded Atropia.

RSOI – 03 1030 – US Gov. 04-07 – p. 15 - Live Event – Key Leader Role Plan/SOF CA – USAID RP conducts engagement with SOF CA at the SOF RUBA. Note: This is ok. Next thread on this subject has the same meeting happening at a different time.

RSOI – 03 1500 – Spartan – p.18 – Live Event – Key Leader Roel Play/SOF CA – USAID RP conducts engagement with SOF CA. Note: This is the same meeting as previous thread but with a different time – 15:00 versus 10:30.

Michael Maxey  
Events Related to Post Conflict Stabilization &  
Non-combatant Emergency Operations  
October 28, 2019

## Honduras 1988

Balancing Mission with Risk.

## Peru Hostage Event - December 17, 1996

Good Diplomacy Promotes Good Security

# Iraq 2008 - 2010

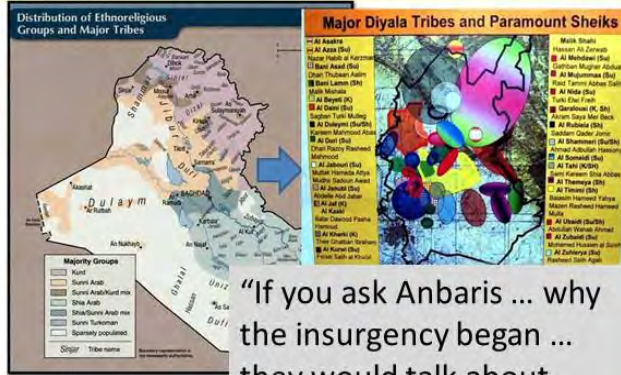
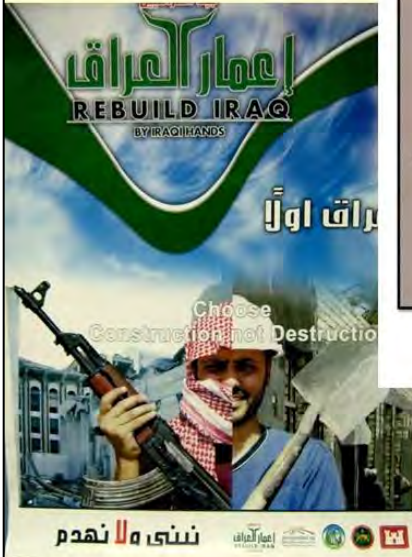

"If you ask Anbaris ... why the insurgency began ... they would talk about mutual misunderstandings and a lack of cultural awareness on both sides.  
Lt. General John Kelly, USMC

Good diplomacy Reinforces Good Security.

# Yemen September 2012



Continuous Training Is Important!

Daily Activities Report  
Michael Maxey  
October 29, 2019

9:00 – 10:00 - Participated in IA Team meeting. Received brief from DCM re daily intelligence meeting. Key points: (1) Ujen has been secured; (2) Civil Affairs Team is being tasked to get into Ujen to do an Essential Services Needs Assessment; (3) apparently RTU will be in Razish on TD 07; and (4) there will be governance meeting on TD 06 (day after tomorrow).

10:00 – 11:00 - Program Manager assisted IA Team in updating Governance Script to be congruent with current status of the training rotation and the Thread. Purposes of the script: (1) provides guidance to SMEs and role players on what the meeting objectives should be and how the meeting should be conducted; (2) OCs are able to understand and assess what SMEs and role players are supposed to achieve in the meeting; and (3) script provides a basis for determining if training objectives are being achieved. A final script was drafted with participation by the whole IA Team. See attached.

11:00 – 12:00 – CPT Tribble called IA Team and discussed upcoming meeting with ethnic leader and governor of Erdabil. During this call, IA Team was able to get details and pass information on about the meeting. It was also discovered that CPT Tribble, CAT Team 3 leader was not going to do the assessment of Ujen. She indicated that Ujen was 70% cleared and that CAT Team 2 under CPT Blythe would do the Essential Services Needs Assessment. The goal seemed to be to have the assessment completed and submitted to Division today.

12:00 – 13:00 – Lunch

13:00 – 14:00 – Summary of USAID Atropia projects was prepared to assist in long term project design and implementation. See attached copy. Key areas of focus would continue to be (1) governance, (2) economic development and (3) health sector. Intermediate actions would include bringing in a Disaster Assistance Response Team (DART) and an Office of Transition Initiatives (OTI) unit.

14:00 – 14:15 – Received Box Phone call from CPT Nathan Blythe, CAT Team 2 Lead. He reported that his CAT Team would be entering Ujen this afternoon. The town is cleared and secured with the turn over to Atropian authorities planned for 14:30 today. The turn-over was confirmed with the Atropian Provincial Police. USAID reviewed the basic information needed in an Essential Services Needs assessment and gave CPT Blythe a summary of the pre-invasion information on Ujen in terms of population and essential services (see attached annotated map). Given the timing, USAID stated that it was doubtful that Essential Services HA would be provided today but that if assessment could be prepared and submitted to CMOC and approved by Division there was a good chance that HA could be provided early tomorrow morning. CPT Blythe said he would do his best and try get the assessment completed and submitted this afternoon.

15:30 – AHA Executive Director called and indicated the NGO is ready for any contingency related to DCs. We agreed to touch base at 9:00 am tomorrow.

**NTC 20-02**

**Script: 1<sup>st</sup> Governance Meeting**

**THREAD:** 04-16

**TIME AND LOCATION:** TD05: time and location TBD

**PARTICIPANTS:** Erdabil Provincial Governor, Provincial Police Chief, US DoS DCM, DATT, USAID, UNHCR, CONS/PDO. Expected: RTU: BDE CDR, R9/S9, CMOC

**Purpose:** Erdabil Provincial Governor Lutf Moheidin, Police Chief Khoskyi and US diplomatic team meets with the BCT to review current military situation and coordinate plans and activities for the days ahead. Issues of focus will be the status of the battle, humanitarian relief operations, progress on the ethnic reconciliation effort and coordination for handover of urban security responsibilities. This is the first high-level US-Atropian coordination meeting since the start of the liberation of Erdabil province and the start of combat operations.

**Note:** This meeting will follow USG-only huddle with the Regiment staff during which DCM will provide update from the Embassy and DATT will provide update on condition of Atropian 350<sup>th</sup> Brigade.

**DCM**

-- Open by reminding all that this meeting is an opportunity to review and sharpen our coordination on issues to help the Brigade and Atropian government deal with the immediate conditions they are facing.

-- Ask BCT to provide a short briefing on the current military situation and plans for the next 24 – 48 hours.

**[Pause for BCT to offer opening remarks and brief on military situation]**

**DATT**

-- Following BCT brief, ask (as needed) for any clarification or further details on BCT military operations.

**Governor Moheidin**

-- Thank the RTU the effort and sacrifices US soldiers are making.

-- Mention that many people are trying to get away from the fighting. Request that any IDPs found should continue to be processed in an assembly area, where we can collect them and move them to the camp we are establishing.

-- Ask the RTU we to be careful about transferring security responsibilities from the US to Atropian police after US forces clear towns and villages. Emphasize that if a security vacuum is left behind US forces, the BFB fighters will try to come back.

-- Point out the importance to do everything possible to ensure that basic humanitarian needs are provided to civilians as soon as possible after a town is secured.

-- Address two other issues: First, that it is important to we continue to concentrate on countering Donovanian propaganda efforts – they are very active, and many people believe their propaganda lies. Suggest that the RTU disseminate messaging that reassures civilians that help is on the way.

-- I also want to thank the US military for arranging meeting with the Lezgin and Bilasuvar leaders. These are important contacts. I hope to meet with both of them at the same time so that we can all discuss how to work together in the future.

**[Pause to allow BCT to respond to the Governor's points]**

#### **CHIEF OF POLICE**

-- Report the key intel points in your threads.

-- Describe the conditions of your police force, and how quickly you would be able to take over security from US forces after the town has been seized. Remind the BCT that you need at least a 24 hours window before you can arrange for a security transfer in the towns.

**[Pause to allow BCT to comment on any issues regarding security handovers.]**

#### **UNHCR**

-- Comment on how to improve handling of the DC operations and point out any issues or coordination to improve handling DC operations. Report that the UN is organizing additional humanitarian assistance in the weeks ahead.

#### **USAID**

-- Remind BCT of the importance of conducting careful assessments of towns cleared by US forces, noting that such assessments will provide the basis for the Atropian government decisions about when to take over security responsibilities and when conditions are adequate for the government to resume functions in those towns.

-- USAID is expecting the arrival of a DART team and later an OTI team – these teams will begin defining long term reconstruction requirements.

#### **CONS/PDO**

-- Reinforce the comment that the Governor made about messaging – that it is important to highlight military success – this is the most effective way we can counter Donovanian propaganda.

#### **DCM**

-- Recaps key issues and takeaways from the meeting.

-- Asks Governor and BCT if they have any last words, then closes the meeting.



## USAID Atropia Brief

Atropia gained its independence in 1983. USAID has provided over \$350 million since 1991 with a focus on two sectors: (1) Supporting the economic growth of non-oil sector; and (2) strengthening democracy and governance. Atropia has provided \$20 million in matching funds to achieve economic reform goals. Current portfolio is funded at \$81.05 million in three sectors: Democracy and Governance (\$39.35 million), Economic Growth (\$33.90 million) and Health (\$7.0 million).

Democracy & Governance – \$39.35 million - USAID works with public sector partners and civil society to strengthen democratic practices and standards of accountability, encourage citizen participation, foster government transparency, and efforts to empower women and combat human trafficking.

Elections - \$5.5 million – IFES

Access to Legal & Policy Information - \$1.2 million – NCSC

Anti-Corruption Project - \$800,000 – Council of Europe

Media Advancement - \$5.75 million – IREX

Independent Media - \$2.5 million – Internews

Community Development - \$11.45 million – CHF International

Atropian Community Security - \$2.7 million – Chemonics

Erdabil Stabilization - \$9.45 million - DAI

Economic Growth – \$33.9 million - USAID supports a business and investment friendly environment and increased trade through economic integration and trade with Europe. Major reductions have occurred in poverty due to opening of gas pipeline Baku-Tbilisi-Ceyhan in May 2005. Non-energy sector lags behind. Focus is on diversification of the economy with a focus on agriculture sector. Support is provided to improve banking efficiency and accountability with focus on promoting market-based financial services to small and medium enterprises. Activities also include work force development, regional trade promotion, etc. This area is also where education support activities are taking place.

Atropia Economic Dev. Project - \$1.5 million – Citizens Dev. Corps

Treasury Information - \$7.3 million – Carana Corporation

Energy Assistance - \$5.5 million – PA Government Services

Municipal Rehabilitation - \$4.2 million – AECOM

Agriculture Projects- \$11.9 million – Farmer to Farmer (\$500,000); Participatory Ag (\$2.4 million); Rural Credit (\$5.9 million); Ag Input (\$3.1 million)

School Economics Education - \$3.5 million – Junior Achievement

Health – \$7.8 million - Support for activities in three areas – (1) TB control, (2) child healthcare and (3) women and child nutrition. USAID programs also focus on strengthening the capacity of the Ministry of Health to advance health reform initiatives, improving the use of health resources and improving the quality of health services.

Child Survival - \$1.3 million – Mercy Corps;

Primary Healthcare - \$5 million – Intl. Medical Corps;

Reg. Water Project - \$1.5 million – PA Consulting

Annotated Map of Erdebil Province with pre-invasion information on key urban areas.  
 Note that Reyalem and Hevroq are in Gorgas.

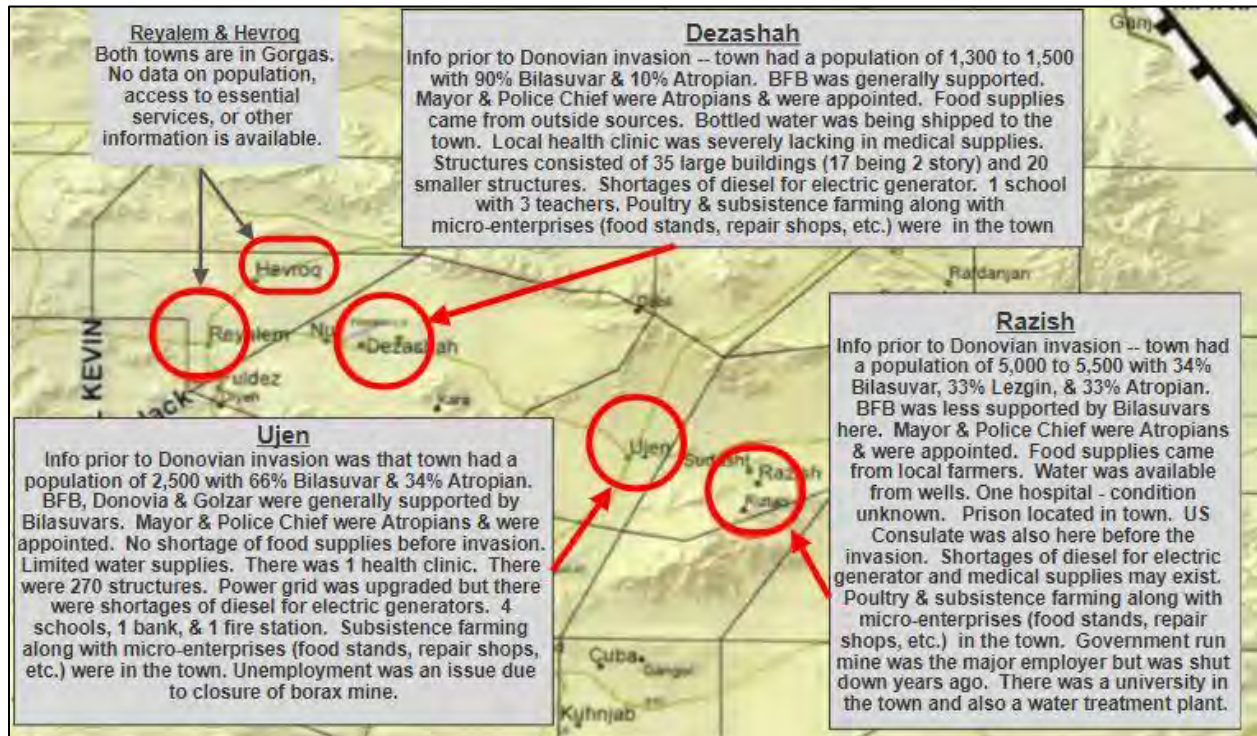

## Daily Activities Report

Michael Maxey

October 30, 2019

9:00 – 9:15 - Participated in IA Team meeting. Received brief from DCM re daily intelligence meeting. Prepared brief for RTU regarding Essential Needs Assessment and the delivery of humanitarian assistance in response to the assessment on Dezashah. See attached.

9:15 – 12:00 – Travel to the Box for IDP event. See attached notes.

12:00 – 13:00 – Lunch

13:00 – 13:30 – OC Brief at 13:13 for Last 24 Hours on radio channel 136. Main Points - Public Affairs - Steadily improving - more active with press releases - need more mentoring on social media. MAJ Richiesen stated that PO team is strong. No word of planning of press release for upcoming liberation of Razish. MAJ Richiesen will reach out to IA (Scott) to have PDO suggest they start thinking about this. IDP Event - Reported sighting of IDPs went out quickly but Regimental was unable to quickly get a CAT team to the right location. Action of CAT team 1 at the IDP event went well after some initial coaching by the IA. SOBE Tomorrow- Role players will stay in the box and keep working. Governance Meeting - Still planned for tomorrow. Assessments - Initial assessment of Razish will start tomorrow. Deliberate assessment is planned for Ugen tomorrow.

13:30 – 16:00 – Prepared summary of assessment procedures for essential services. See attached. Prepared schematic and shared with CMOC in order to respond to their request for assistance with a deliberate essential services assessment in the field.

16:00 – 17:00 – Review and clearance on Initial Essential Services Needs Assessment of Ujen. See the attached schematic summarizing the assessment and USAID's analysis and recommendation. Copy of the RTU assessment of Ujen is attached as well.

## Report on IDP Event –

9:40 - Departed for IDP event NW of Ujen (coordinates NV 368 119).

9:58 - Monitoring radio channel 136, heard via OC chatter that CMOC had spotted IDPs and was getting a CA Team out to address the situation.

10:11 – Radio chatter indicated CAT Team was moving toward IDP site NW of Ujen.

10:13 – Email received from CMOC indicating RTU was informed of a large group of IDPs moving toward Ujen (1,000 IDPs).

10:39 – Provost Marshall CPT Paul called UNHCR Rep with grid of IDP location which coincided with location of RSA (NV 321-169).

10:49 – CAT Team requested assistance from UNHCR, USAID and AHA. We moved in to assist with IDP processing and transportation to camp within Atropia.

10:55 – Approximately 75 IDPS were congregated around the entrance to base camp with CAT Team 1 (CPT Kawasaki) standing near the IDPs but not effectively engaging them.

10:56 – 11:31 - UNHCR Rep advised CAT Team of the actions that were needed and CAT Team acted with support from Engineering Company at the RSA. They did the following: (1) set up a controlled area to process IDPs, (2) separate men from women, (3) process the group – men processing men and women processing women; (4) separate out any CCHF infected individuals; (5) remove weapons from any civilians, take down the serial number and give the civilian a receipt to receive the weapon at an appropriate time, and (6) check IDs, take down numbers and ensure an accurate count of IDPs matched against list of names. No IDPs were confirmed to have CCHF. AHA provided HA to IDPs that had been processed. At that point, UNHCR Rep stated that they could have the processed IDPs board a bus for transport to a camp inside Atropia. IDPS left to board the bus.

11:35 – UNHCR and USAID departed as did AHA.



IDPs NW of Ujen

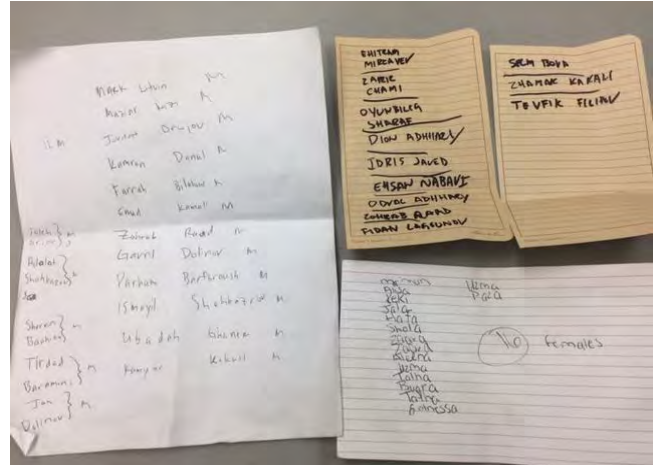

List of IDP names.

MACH LHAM M  
 KASIM LAM M  
 JAWAR DAWUD M  
 KAMAR DANAL M  
 FARAH AHMAD M  
 SAUD KAMIL M  
 ZAYED RAJAB M  
 GAYRI DULMAN M  
 YAKHAN BARBARAH M  
 FAROOL SHAKHRIYAH M  
 LUBA DAK SIAMBA M  
 KAMPAR KUBIL M

EHSAN NABANI  
 OSMAN ADHANI  
 IDRIS JAVED  
 OSMAN ADHANI  
 SAUD KAMIL  
 FADAN LAHMAN

SELM DOKA  
 ZAHAR KAKALI  
 TOVRK FILIN

10 females

**Field Operations for Disaster Assessment and Response: Key Percepts**  
**US Agency for International Development**

**Distinguish between Emergency and Chronic Needs.**

Use existing information to determine baselines for key sectors (access to food, water resources and access, shelter and overall access to essential services). Quickly identify short term versus long term needs. The initial needs assessment identifies sources and services for immediate emergency measures to save and sustain the lives and livelihoods of the affected population. It provides the basis for a rapid response to help lower excessive death rates and stabilize the nutritional, health, and living conditions among the at-risk population.

**Assess Needs and Vulnerabilities in Relation to Capacities**

- Needs (water, food, shelter) are immediate requirements for survival. Vulnerabilities are potential areas for harm and include factors that increase risks to the affected population (lack of adequate economic and health infrastructure, need for economic development activities).
- Needs are expressed in terms of requirements (food, water, shelter); vulnerabilities are expressed in terms of their origins (physical/material, social/organizational, attitudinal). Capacities are the ability of the affected population to meet their own needs. Assessing needs, vulnerabilities and capacities allows the humanitarian assistance provider to (1) prevent an expansion of the emergency, (2) target assistance to the most vulnerable population, and (3) support locally led sustainable recovery.
- Needs are short term – Vulnerabilities are long term areas of concern – We meet short term needs while supporting increased local capacity to take on long term vulnerabilities. Respond to the most urgent but keep an eye on longer term needs.



**Initial Needs Assessment** – The following areas should be addressed: (1) area affected by the conflict (location and size); (2) number of people affected by the conflict; (3) emergency medical, health, nutritional, water and sanitation situation; (4) damage to infrastructure, homes, ag and food crops, water systems, economic resources and social organization; (5) vulnerability of affected population to expanding impacts of emergency situation; and (6) type and level of support from national government, multi-lateral and bi-lateral aid organizations.

**Initial Needs Assessment Check List**

- Introduction
- Displaced Population Profile
- Food
- Nutrition
- Health
- Water
- Sanitation
- Shelter
- Agriculture & Livestock
- Logistics
- Infrastructure

Promote self-sufficiency in the affected population from the start. Involve them in the planning for their welfare. This task may be difficult, but if the affected population is not involved, the effectiveness of the emergency assistance will be severely reduced, and an early opportunity to help them to start recovering from the psychological effects of their ordeal may be missed.

**Ujen**

Info prior to Donovanian invasion was that town had a population of 2,500 with 66% Bilasuvay & 34% Atropian. BFB, Donovania & Golzar were generally supported by Bilasuvays. Mayor & Police Chief were Atropians & were appointed. No shortage of food supplies before invasion. Limited water supplies. There was 1 health clinic. There were 270 structures. Power grid was upgraded but there were shortages of diesel for electric generators, 4 schools, 1 bank, & 1 fire station. Subsistence farming along with micro-enterprises (food stands, repair shops, etc.) were in the town. Unemployment was an issue due to closure of borax mine.



**Assessment - Essential Services**  
**CAT Team 2**

Current Population - 2,500 residents

- Water - 1 week supply available - normal supply from Razish disrupted by conflict.
- Food - 1 week supply available - wheat is in short supply for bread.
- Medical - No CCHF but major shortage of antibiotics and non-opioid painkillers.
- Shelter - No information provided.

\* Security situation is that US military has cleared and secured town with turnover to Atropian government and local police chief imminent.

**USAID Atropia**  
**Assessment for Essential Services**  
**Needs in Ujen, Erbil Province**

RTU identified critical Essential Services needs as food and water. Some medical supplies are needed. There was no information provided on shelter needs. Total population was determined to be 2,500. USAID recommends the following HA be sent to Ujen as soon as possible.

- **Water** - Based on 10 liter minimum per person survival ration, USAID will send via All Hands Atropia 75,000 liters (1,875 gallons) of water. Sufficient for 3 days.
- **Food** - Based on 2,000 kcal/person/day minimum, USAID will send 7,500 meal packs comprised of 430 grams of wheat flour, 45 grams of beans/peas, 25 ml of cooking oil and 5 grams of salt.
- **Medical** - Limited supplies of antibiotics and Ibuprofen painkillers will be sent to Ujen.

## Daily Activity Report

Michael Maxey

11/01/2019

9:00 – 11: 00 - DCM provided brief to Inter-Agency Team: Razish is liberated and Barasu is next but there was an incident that might complicate the situation – a mosque there was hit by the RTU – not sure what the impact will be but civilians were killed in the attack. IA Team discussed upcoming actions regarding a press conference planned for liberation of Razish. More to follow on that. IDP movement was heard on radio chatter (Channel 136) and plans were made to head out at noon to pre-position.

11:00 – 12:00 - CMOC CPT Richardson requested information on towns yet to be liberated (Barasu and Nabran). USAID Rep. put together a schematic showing pre-invasion information for those towns with explanation that it was unknown who the local authorities are since the Donovanian invasion. See attached graphic.

12:00 – 16:00 - UNHCR and USAID Reps traveled to Razish and pre-positioned to be able to assist with an IDP event. See attached log of the events for the day. Also see photos at <https://photos.app.goo.gl/v4xK7oYxbzhNokHYA> of the IDP event today Razis

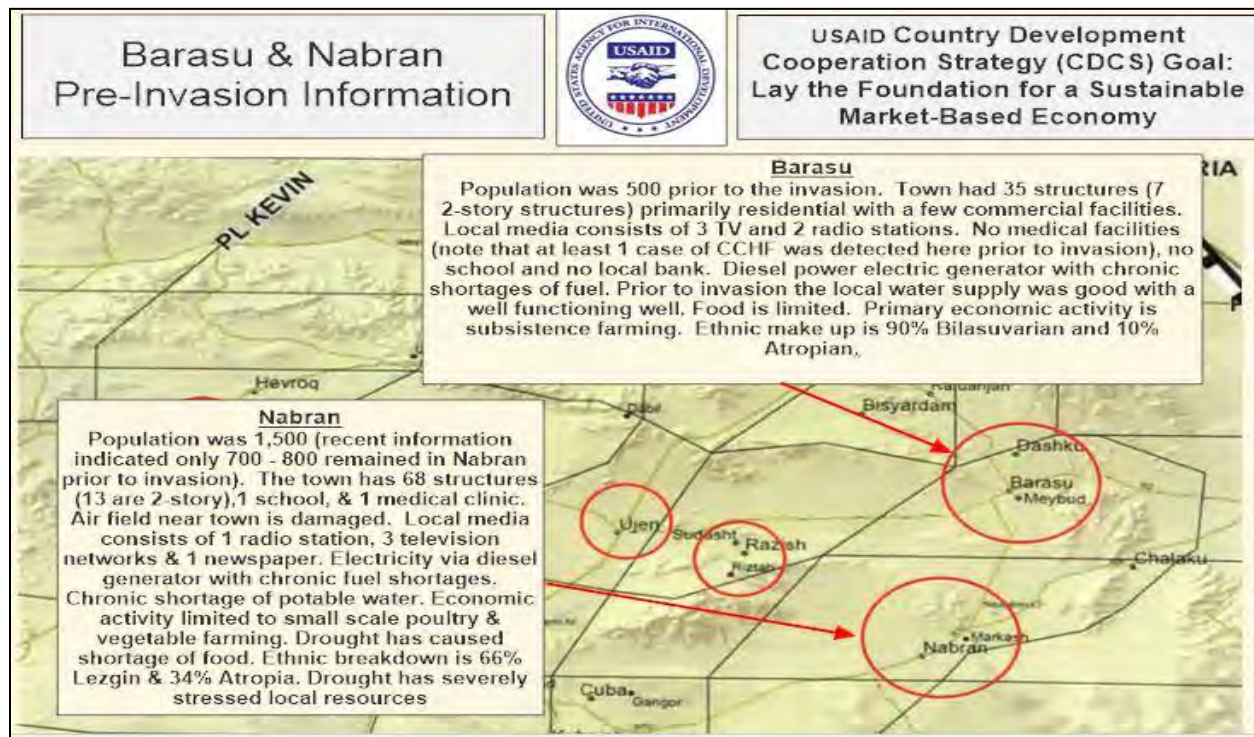

IDP Event TD-07

Michael Maxey

12:15 – UNHCR and USAID Reps depart base with All Hands Atropia director (Samira) and driver (Samir). Group arrives near Razish at 12:38. Teams pre-position and wait for call for assistance regarding an IDP event.

13:05 – Radio chatter (Channel 136) indicated CAT Team 2 led by CPT Blythe has departed Razish traveling to the TOC to do an information download (they were going to essentially pass on the Essential Needs Assessment to the CMOC for Razish).

13:30 – BFB convoy was spotted going into Razish. Gunfire erupted and there was confusion with the IDPs who were arriving at the same time in Razish.

13:59 – IDPs were caught up in the confusion of the BFB attack.

14:13 – Radio chatter indicates the IDPs were found and moved to the US Consulate Building in Razish. Shooting could be heard from the city.

14:38 – OC contact indicates that UNHCR, USAID and AHA should proceed to the city within 10 minutes.

14:48 – UNHCR, USAID and AHA arrive at the US Consulate Building. IDPs are inside the compound. CAT Team 2 is onsite and has initiated processing of the IDPs. CPT Blythe conferred with UNHCR for procedures for handover of IDPs and then began processing them.

15:00 – AHA entered the compound and gave water and food to the IDPs.

15:26 – Processing of IDPs was completed, list of names matching the head count was turned over to the UNHCR, and IDPs were loaded on to buses for unidentified IDP camp.





## Daily Activity Report

Michael Maxey, USAID Rep.

November 2, 2019

Met with IA Team at 9:00 for brief from Program Manager on Razish meeting and press conference planned for today. Humanitarian Assistance (HA) will be delivered prior to the meeting with Gov. Moheidin in Razish. Press conference with COL. Overland, Gov. Moheidin and two ethnic leaders (Iosif Ferdowsian, Bilasuvar Freedom Now Movement (BFNM) Leader, and Azaad Yaqub Bazar, Lezgin Now Leader).

Attended meeting between Gov. Moheidin, COL Overland, DCM Scott McGehee, COL Khosky, Mayor of Razish and the two ethnic leaders Iosif Ferdowsian and Azaad Yaqub Bazar. See attached chronology and notes. Photos of the meeting can be found at <https://photos.app.goo.gl/EL7x4DZw9XYmRvnVA>.



## Meeting in Razish

TD 08

9:50 - IA Team departs for Razish.

10:28 – IA Team arrives in Razish.

11:09 – Gov. Moheidin welcomes the participants to the meeting Stating that this is both a military and a political victory. Thanks was given to the RTU for taking care of IDPS. US Inter-Agency group was thanked as well.

COL Overland: Stated that he wanted to continue working with the Atropia government and ethnic leaders to help stabilize the areas that have been cleared and secured. He thanked the efforts of the Inter-Agency Team for their support to this effort.

Iosif Ferdowsian: Thanked LTC Gavin for promoting a dialogue with Atropian officials. He indicated progress is being made in these discussions and reconciliation is possible.

DCM: Indicated he had been fortunate to participate in these meetings and it was good to see the progress that has been made.

Azaad Yaqub Bazar: Stated that it was important to see the progress made in terms of security and stability. He indicated that the change must be permanent and that the equity that has been sought must be part of this change.

Gov. Moheidin: Assured both ethnic leaders that equitable treatment of all Atropians would be a permanent change in Erdabil province. He asked the Mayor of Razish if he had any comments.

Mayor Yusuf Shabazz: Said that he wanted to thank the American forces for liberating Razish. He stated, “Now that the invaders are gone and we received initial HA but there are many needs of the people that still have to be met: water, power, food, medical supplies and food.”

DCM: “It is good that Razish has gotten HA but are there other immediate issues that need to be addressed? Is there an issue with unexploded ordinance?”

LTC Gavin: “We will work with the mayor and other authorities to address unexploded ordinance.”

UNHCR Rep.: “The UN can help with this effort.”

COL. Khoyski: “We hope to have support from Baku as well for addressing this issue.”

Gov. Moheidin: “Yes, we have to start rebuilding.”

COL Overland: “And we want to support your efforts along with the Inter-Agency Team.”

12:00 The group departs for a press conference.

12:30 – Press conference ends and everyone departs.

13:00 – IA Team arrives in Contonment.



20-02 Threads



## 3<sup>rd</sup> Cavalry Regiment



## AGENDA:

- Area of Operations
- OE Conditions and GRINTSUM review
- Mission and Intent
- Rotation Overview
- Training Day Thread Summary
- Town Conditions
- Key Event CONOPs

# Area of Operations

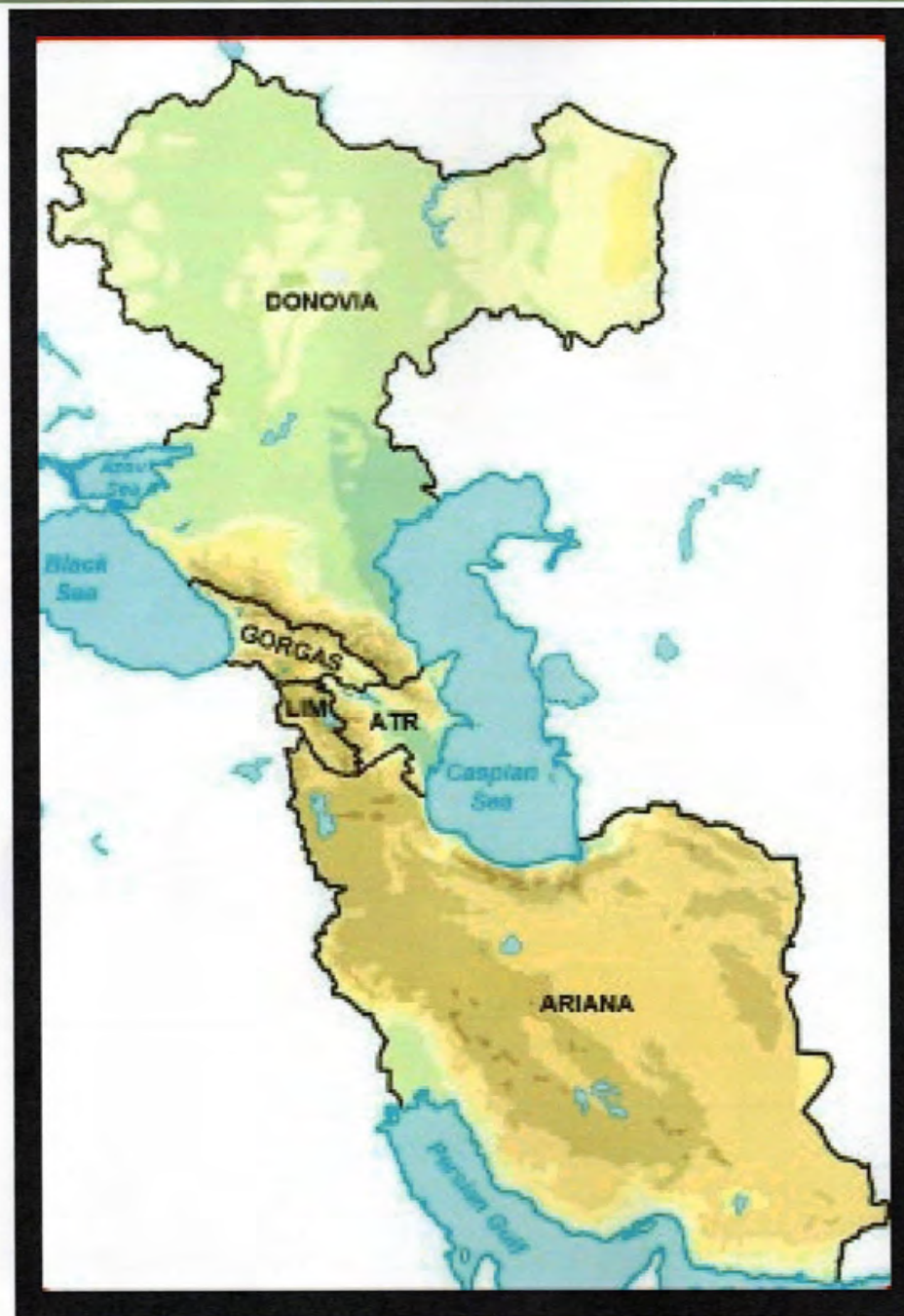

# Area of Operations

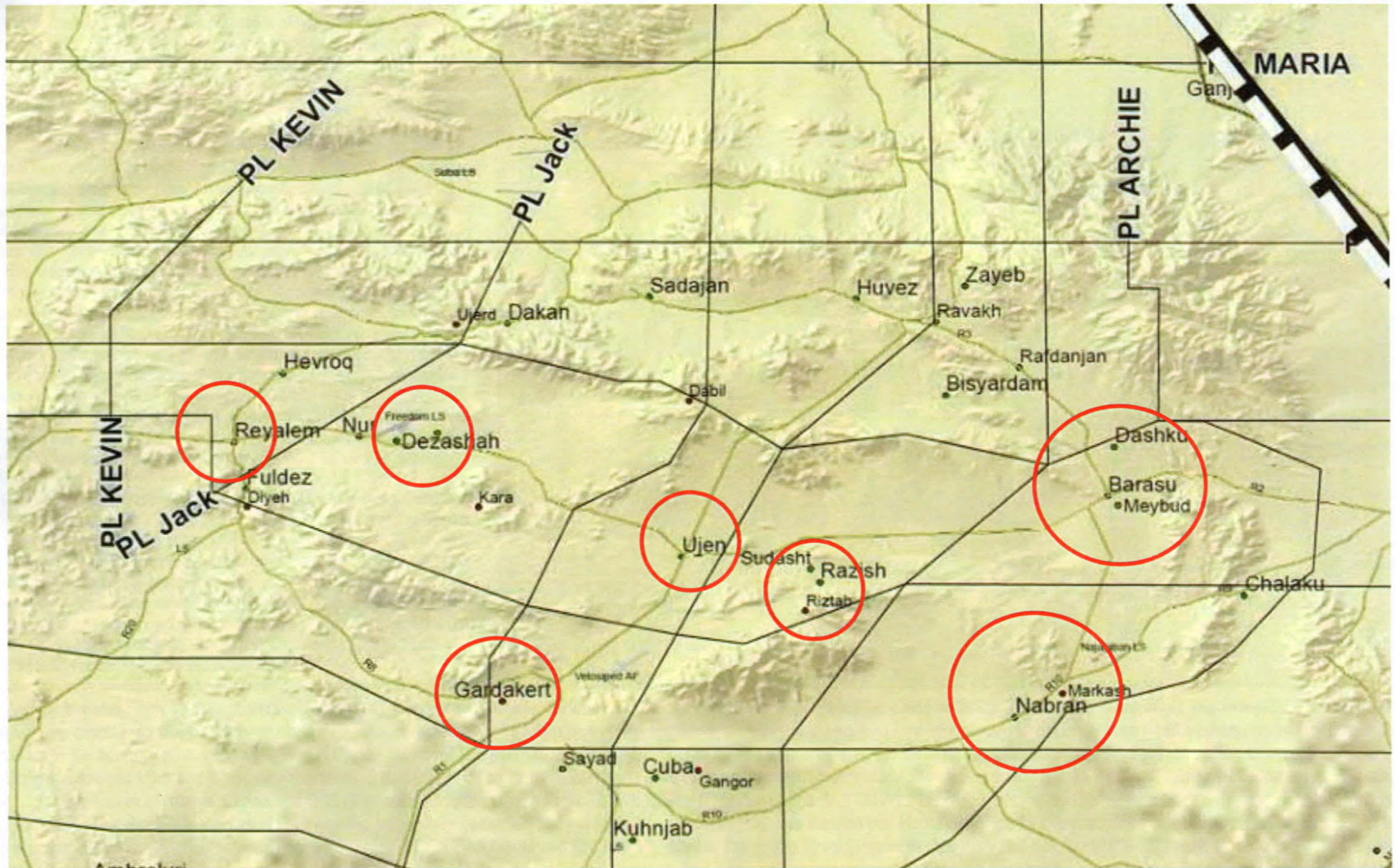

## REGIONAL GRAPHIC INTELLIGENCE SUMMARY FROM 1 TO 22 SEPTEMBER 2019

- 04 Sep** - The U.S. calls for the UNSC to convene to pass a Resolution granting Chapter 7 authorities in the event deterrence of Donovan aggression fails.
- 05 Sep** - The Donovanian President vehemently protested the Resolution and vowed to defend his regional interests and sovereignty with military force.
- 06 Sep** - The US President makes a speech at the United Nations strongly warning Donovan to avoid miscalculation and cease fomenting violence and promoting instability within Atropia and throughout the region.
- 07 Sep** - FDO 4 (C-DAY) commenced with the reorganization of the Joint Task Force from a service component to a Combined Functional Command and unit deployments based on a Time-Phased Force Deployment List. This FDO continues to create a force with the capability to defeat a Threat State invasion and drive the enemy from Atropian territory.
- 09 Sep** - The UNSC passed Resolution 5826 providing Chapter 7 authorities under Article 42. The Security Council authorizes Member States, acting in cooperation with the Secretary-General, to take all necessary measures to restore peace and order in northeast Atropia, ensure Atropia's continued sovereignty over its border, protect civilians and civilian populated areas under threat of attack and requests the Member States concerned inform the Secretary-General immediately of the measures they take pursuant to the authorization conferred by this resolution.
- 10 Sep** - **The US Department of State goes to 'Ordered Departure' status. All USG non-essential personnel and families depart Atropia. Department of State assists any private American citizens who wish to depart Atropia.**
- 17 Sep** - POTUS declares W-Day and issues presidential directive, based on UNCR 5826, authorizing deployment of forces to the Republic of Atropia for offensive operations.
- 21 Sep** - OSC-S fired a surface-to-surface missile and struck Rimzi Airbase in Hachzi Province shortly before midnight.
- 22 Sep** - **OSC-S southern air division conducted an air assault with tactical fighter jets on major population centers and attacked Atropian 352(TANK) BDE fighting positions along the IB and northern coastline. Tenth of thousands are fleeing occupied urban centers.**

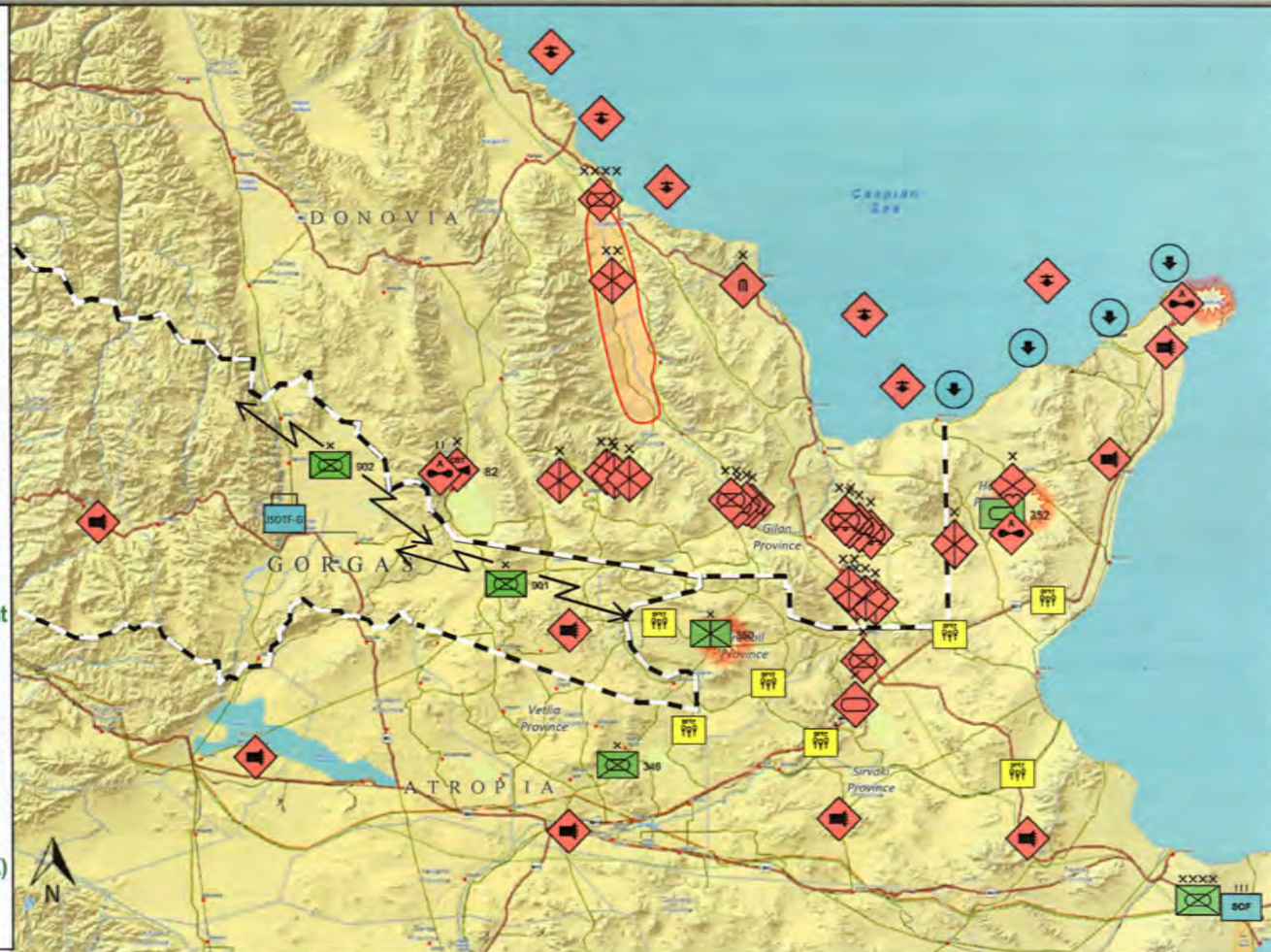

**Analyst Comments:** On 18 Sep, Donovania conducted a regional and international media campaign. Across cyberspace and satellite TV Donovania denounced the Atropian actions in Erdbil Province as counter to the people's right to self-determination and freedom from tyranny. More alarming, it shows evidence of widespread atrocities committed by Atropian military forces against ethnicities in the northern provinces, especially in Erdbil province. The international community begins raising concerns over the methods Atropian security forces are employing to wrest control back from pro-Donovanian sympathizers and Bilasovar separatists. U.S. Intelligence confirm the vast majority of the so-called evidence (footage showing atrocities committed by Atropian military forces) is fabricated and false. After three days of relative silence, the OSC-S invaded Atropia's Hachzi Province with tactical fighter jets. The 352(TANK) BDE (ATR), spread thin throughout Hachzi Province has lost 50% of their combat power within the first few hours of the invasion. Intelligence confirmed that the 83 Airborne Infantry BDE has inserted into Hachzi Province near Lozari. Further intelligence identified the 820(MTZD) BDE crossing the IB into Hachzi Province and two separate BDEs, 840(TANK) and 850(MECH), crossed the IB into Sirvaki Province. It is assessed that the 820(MTZD) BDE along with the 83 ABN IN BDE will attack to destroy the remnants of the 352(TANK) BDE spread thin throughout Hachzi Province, then seize and control major urban centers to cutoff the province from the rest of Atropia. Four DTGs, the 84(MTZD), 86(MTZD), 80(MECH), and 81(MECH) are currently arrayed along the IB with Atropia. Within the next two to four weeks Donovania will move further into Atropia and will prepare defensive positions to repel any attempts by Atropian or coalition forces to disrupt or prevent Donovania from seizing Atropia's capitol Baku.



## 52ID (M) GRAPHIC INTELLIGENCE SUMMARY FROM 1 TO 22 SEPTEMBER 2019

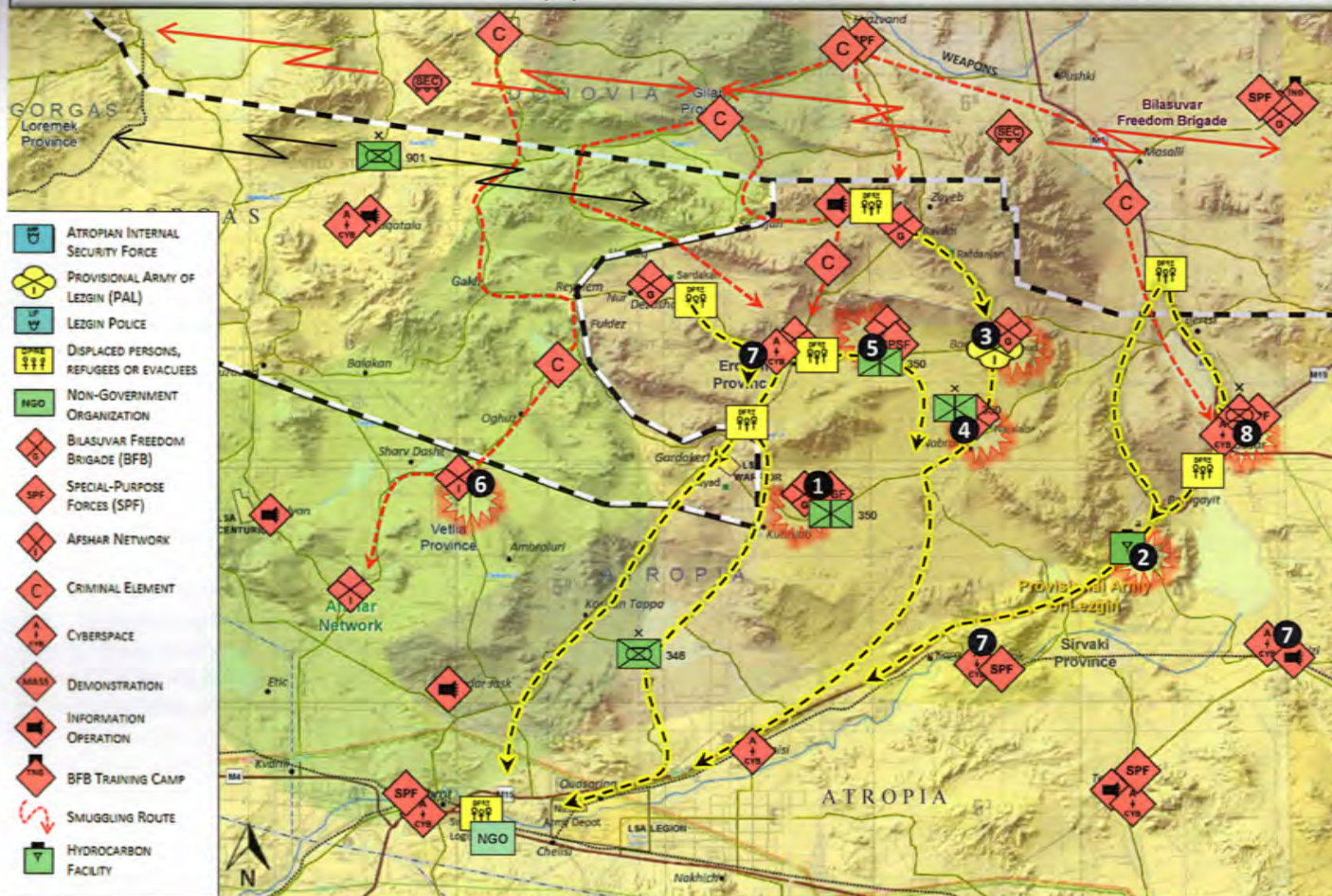

01 Sep – Intense fighting between Atropian Army and BFB/EPSP fighters near Kuhnjab.

02 Sep - Reports of explosions and gunfire occurred near a hydrocarbon facility in Sirvaki Province.

03 Sep - BFB defeated PAL in Barasu and took control of the town.

06 Sep - Governor Golzar travels to Gilan Province, Donovania to avoid possible apprehension by Atropian forces in Erdabil.

04 Sep - The 350 MTZD IN BDE (ATR) clears Nabran. The BFB fled north to Barasu.

05 Sep - The 350 MTZD IN BDE (ATR) is struggling to defeat the BFB in the heavily fortified city of Razish, the capitol of Erdabil Province.

06 Sep - A UN convoy was attacked en-route to Dezashah, Erdabil province to deliver medical supplies and aid. The AFN claimed responsibility for the complex attack.

07 Sep - A possible Denial of Service (DoS) cyber attack targeted Atropia's power grid causing widespread blackouts in Erdabil and Sirvaki Province.

08 Sep – Donovanian forces crossed the IB south into Sirvaki Province, Atropia and seized Gusar taking control of a main supply route to and from Swabrot, Vetlia Province and Rimzi, Hachzi province.

**Analyst Comments:** The 350 MTZD IN BDE entered Erdabil Province to restore Atropian Government control. Within hours, Donovania laid claim to Erdabil Province and denounced Atropia's incursion into Erdabil Province as an illegal act against its sovereign land. The next day the Atropian government tried Governor Golzar in absentia for his treasonous activities to secede Erdabil into Donovania. For almost a week, intense fighting occurred near Kuhnjab in the southeast of Erdabil. Meanwhile, BFB in the eastern and northeast Erdabil defeated PAL and took control of Nabran and Barasu, any PAL members still alive fled south. Governor Golzar left Erdabil Province with some of his EPSP to avoid possible capture by the 350 MTZD IN BDE (ATR). The northern provinces of Atropia experienced widespread blackouts, and insurgents blocked the delivery of much needed fuel and food to population centers near the border towns. Criminal elements, benefitting from the escalating violence, continue the profitable cross-border weapons trade in the already thriving black market. The security situation deteriorated even further when BFB attacked major population centers in Erdabil Province. Thousands of Atropians are fleeing border towns creating a humanitarian crisis, clogging roadways, and overwhelming cities in southern Vetlia and Sirvaki Provinces.

## REGIONAL GRAPHIC INTELLIGENCE SUMMARY FROM 23 SEPTEMBER TO 22 OCTOBER 2019

- 23 Sep** - The Atropian Supreme High Command deployed the 344 Mech and 354 TANK BDE from the western Janga Province in the west to reinforce defensive positions in Tramaz Province to protect the Atropia's capitol, Baku.
- Four U.S. Mechanized (M) Infantry Divisions (ID) and one Armored Division (AD) from Great Britain continue to deploy into the region at a rate of one division a week.
- 24 Sep** - The 81 MECH DTG seized Gusar, Sirvaki Province and took control of two major communication lines (MSR GETTYSBURG and FREDRICKSBURG).
- 28 Sep** - 86 MTZD DTG following the 81 MECH DTG seized Bamgayit and took control of gas and oil plants near Bamgayit along the M15.
- 30 Sep** - Intelligence confirmed the 850 MECH, 820 MTZD, & 840 TANK BDEs established battle positions along main avenues of approach north of the IB with Gorgas.
- 7 Oct** - The 84 MTZD DTG is observed crossing the IB moving south along the M1.
- 13 Oct** - Coalition forces began an air campaign targeting Donovanian command and control, air defense networks, and airfields to deny Donovia the opportunity to challenge the CF aerial onslaught. Additionally, bridges and major roads were bombed to cut off routes for reinforcements.
- Meanwhile, CF forces conducted deception operations to mislead the Donovians by saturation bombings of Donovanian battle positions north of the border between Gorgas and Donovia to leave Donovia guessing about where the CF breach would occur.
- 15 Oct** - CF diversionary actions prompted the Donovians to send the 84 MTZD DTG to move southwest to block CF, ordered a fighter jet squadron to Nazgul air field to guard against CF breaching into Donovia, and ordered the 86 MTZD and 81 MECH DTG to dig in, reconsolidate, and resupply.
- 18 Oct** - The Atropian Navy launched amphibious feints and naval gunfire along the Caspian coast of Hachzi and Tramaz Province to add to a third possible CF breach location, therefore spreading OSC-S forces out in all directions.
- 20 Oct** - The interdiction of supply lines by CF aircraft weakened the 86 MTZD and 81 MECH DTG. Both DTGs established a defensive line north of the M4 (MSR BATON ROUGE) against a possible Atropian counter attack from the southeast.

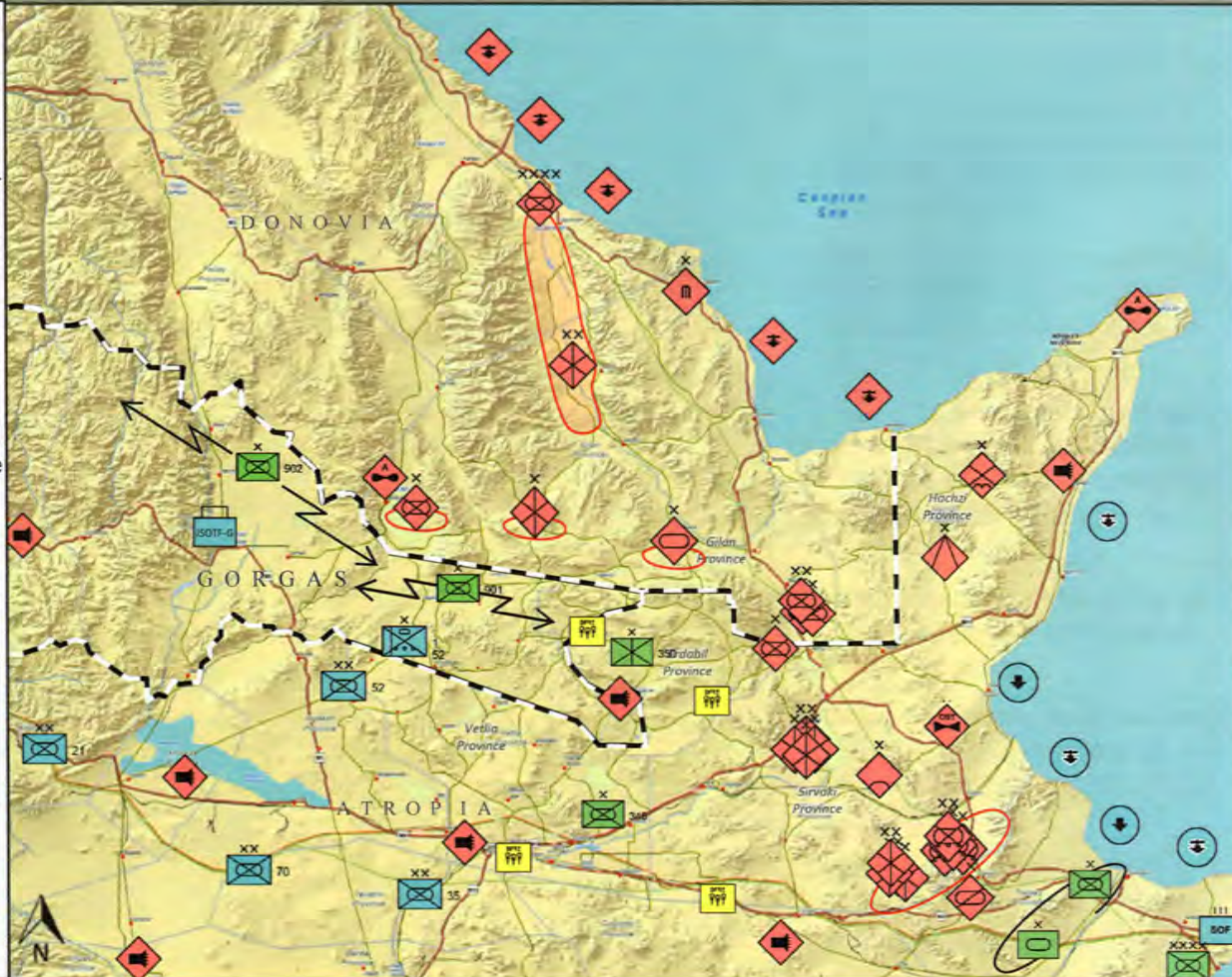

**Analyst Comments:** At the end of last reporting period, OSC-S invaded Atropia with air, airborne infantry, and ground forces into Hachzi and Sirvaki Province. Previous reports identified the 840(TANK) and 850(MECH) BDEs crossing the IB into Atropia. New intelligence identified that it was the 81 MECH DTG followed by the 86 MTZD DTG crossing the IB into Atropia. Neutralizing Atropia's 352 TANK BDE in Hachzi Province and fixing the 350 MTZD BDE in Erdabil Province enabled the OSC-S to seize key terrain and major population centers within the first two weeks of the invasion. The Atropian military counter attacked during the invasion but had to withdraw under pressure or withdrew to preserve combat power. Atropian forces established a defense north of Baku. **The Donovanian offensive has resulted in the displacement of 100,000 people in northern and central Atropia in the past month creating a humanitarian crisis.** Expect the OSC-S to emplace defensive barriers, obstacles, and minefields along the flanks of its advancing force (81 MECH DTG). Currently the OSC-S is located along the provincial boundaries of Tramaz conducting resupply operations to resume offensive while consolidating control over territorial gains. OSC-S estimated strength is assessed at 90% and their reserve at 50%. One armored division from Great Britain (12AD) and three mechanized infantry divisions (70ID, 35ID, & 21ID) are 85 to 90% complete with deploying their forces and 52ID(M) is 95% complete. Expect Donovanian forces to block coalition forces from interfering with the seizing of Baku by the 81 MECH DTG within the next five days.

## 52ID (M) GRAPHIC INTELLIGENCE SUMMARY FROM 1 TO 22 SEPTEMBER 2019

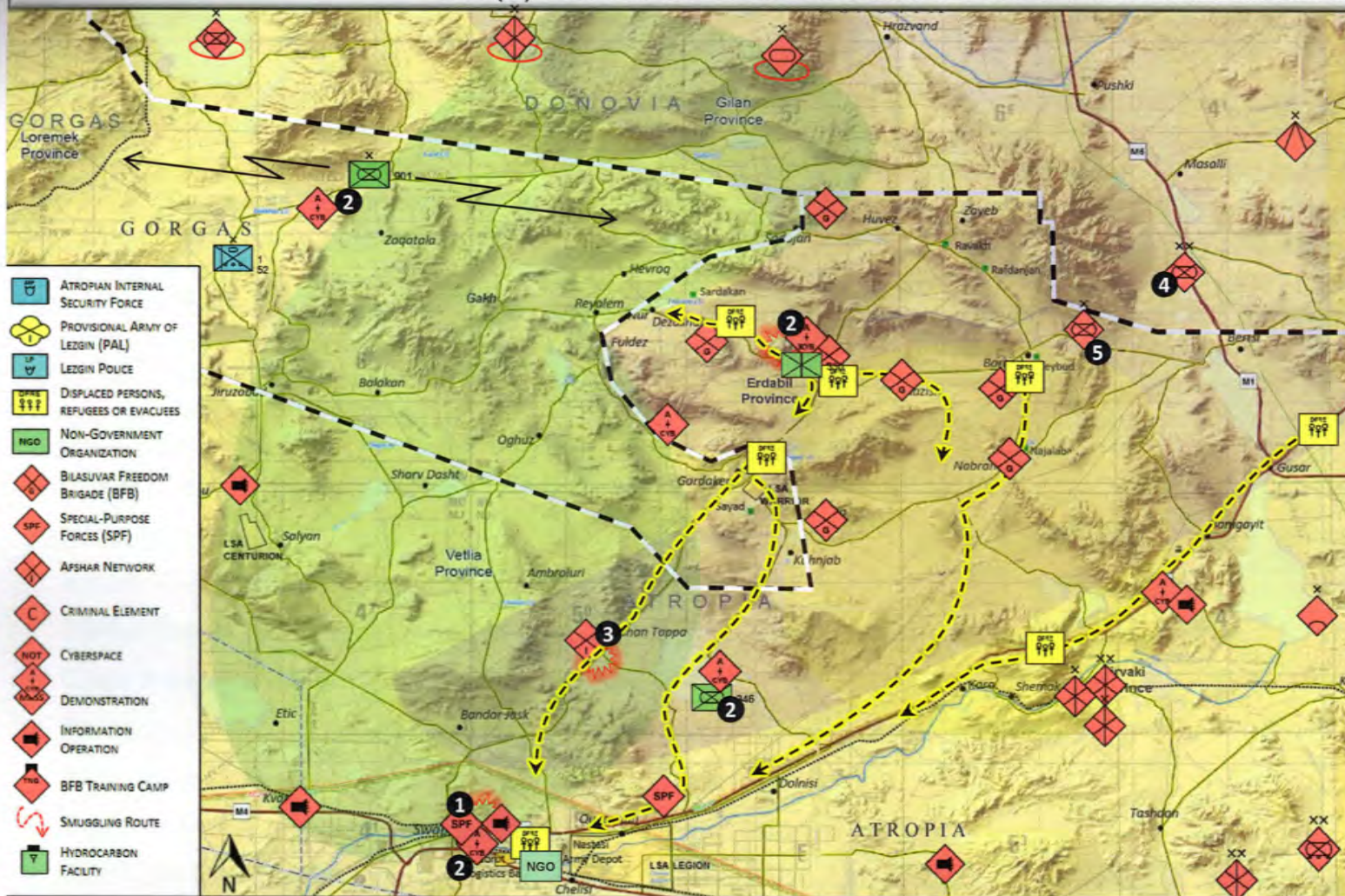

**23 Sep** - Several attacks conducted **1** by the AFN occurred against ANP and government buildings in Swabrot, Vetlia Province. and executed by AFN.

**29 Sep** - The Atropian government **2** reported a cyber attack that prevented communications to their military forces

**12 Oct** - The AFN intercepted and **3** diverted several deliveries of supplies destined to population centers in Erdabil Province.

**18 Oct** - The 80 MECH DTG moved **4** from Masalli to north of the IB and is stationary northeast of Berts, Atropia.

**20 Oct** - The Donovanian government took widespread control of cyberspace and satellite TV in Atropia.

**21 Oct** - The 801 MECH BTG is **5** observed crossing the IB into Erdabil Province in the east.

**Analyst Comments:** Since the Donovanian Invasion, the 350 MTZD BDE is controlling only parts of Erdabil Province west of RTE 1 (MSR BULL RUN). Currently estimated at 58% strength, the 350 MTZD BDE's is guarding and protecting supply lines, ASR IA DRANG and MSR BULL RUN. It is assessed the 350 MTZD BDE will withdraw within the next 3-5 days due to loss of combat power. The ongoing violence by BFB elements within Erdabil Province, attacks on relief convoys by Afshar Network in Vetlia Province, and the weakness of the Atropian government has hindered humanitarian relief efforts, the delivery of supplies, and the work of humanitarian assistance agencies. Ethnic Atropians have been systematically driven from their towns and villages by Donovanian sympathizers and BFB. Donovanias continues CEMA and IW operations planting viruses, computer worms and malware taking down military systems vulnerable to cyber attacks. It is assessed the 80 MECH DTG and the 84 MTZD DTG, currently located east of Shemak, Sirvaki Province, will try to block the anticipated CF attack to protect OSC- It is assessed the 84 MTZD DTG currently east of Shemak, Sirvaki Province will move west to block

# Mission and Intent



**Mission.** O/O, 52ID attacks to defeat Donovanian forces within Vetlia, Erdabil, and Sirvaki Provinces to prevent further Donovanian aggression, and reestablish Atropia's international border.

**52ID Commander's Intent.** **The purpose of our operation is to ensure the territorial integrity of Atropia.** As Donovanian attacks CF throughout Atropia, whether by conventional and unconventional forces or proxy irregular forces, we will combine Offensive, Defensive, and Stability Operations in Atropia's Erdabil, Vetlia, and Sirvaki Provinces. Decisive to our operation is seizing M15 and the Trans Caucasus Petroleum and Gas Pipelines (TC-P/G) in Sirvaki Province and control over logistic nodes within Swabrot. Simultaneously, we conduct shaping operations to defeat Donovanian forces in Erdabil and Vetlia Province, which protect the northern flank and rear of the Division's main effort. Once OSC-S offensive forces reach culmination, the Division will attack to destroy, capture, or force the withdrawal of Donovanian forces from sovereign Atropian territory. In conjunction with Offensive and Defensive Operations, it is imperative that we clear the provinces of defeated and bypassed Donovanian regular forces neutralize irregular anti-government elements and retain the provincial territory. Operations performed throughout all Phases of this operation promote the host nation Governments' legitimacy by enabling Atropian security forces; furthermore, we must ensure Stability Operations take place in conjunction with US Department of State initiatives to achieve a unity of effort on behalf of the American people and our coalition allies.

## **Key Tasks.**

- Retain M15 and M4 Corridors.
- **Defeat Donovanian offensive capabilities south of the International Boundary (PL ANNIE).**
- **Clear Atropian territory of Donovanian forces.**
- Re-establish control and defense of the International Boundary with Donovia.
- **Neutralize insurgent / separatist elements.**
- **Support GoRA in restoring essential services and internal security.**
- **Facilitate Non-Governmental Organization (NGO) / Private Volunteer Organization (PVO) humanitarian assistance to displaced civilians, refugees, and indigent civilians impacted by the operation.**

**Endstate.** **All Donovanian forces that entered Vetlia, Erdabil, and Sirvaki Provinces destroyed, captured, or expelled.** Separatist and anti-government elements are defeated and unable to influence the population of all three (3) provinces. Atropia in control of M15 and M4 corridors. 52ID prepared to transfer control to follow-on United Nations Observer Forces. Vetlia, Erdabil, and Sirvaki Provinces are secure and civilians are returning to their points of origin while not interfering with Coalition operations. **Essential services restored to the population and 52ID is supporting governance and infrastructure development. 52ID forces transition all stability and internal security operations to the Government of Atropia and/or follow-on authorities.** 52ID initiates redeployment operations.

## 52ID Tasks to 2/1 AD (A)



- Receive Operations and Intelligence Brief from 350(MTZD) BDE leadership on 231500OCT19.
- Participate in all Atropian joint press conferences with the Atropian Minister of the Strategic Integration (MOSI).
- Participate in all State Department Working Groups
- Conduct Displaced Civilians/Refugee Support Operations back brief to 52ID NLT 241600OCT19 through CPOF.
- BPT support to Host Nation Forces in the movement of displaced civilians to secure locations within Erdabil Province.
- Transition control and security of population centers to Atropian Authorities within 72hrs following seizure or clearance.
- Conduct civil reconnaissance and submit initial civil assessment to 52ID G9 NLT 24hrs after seizure or clearance IAW Annex K.

# 20-02 Rotational Calendar



## OCTOBER / NOVEMBER

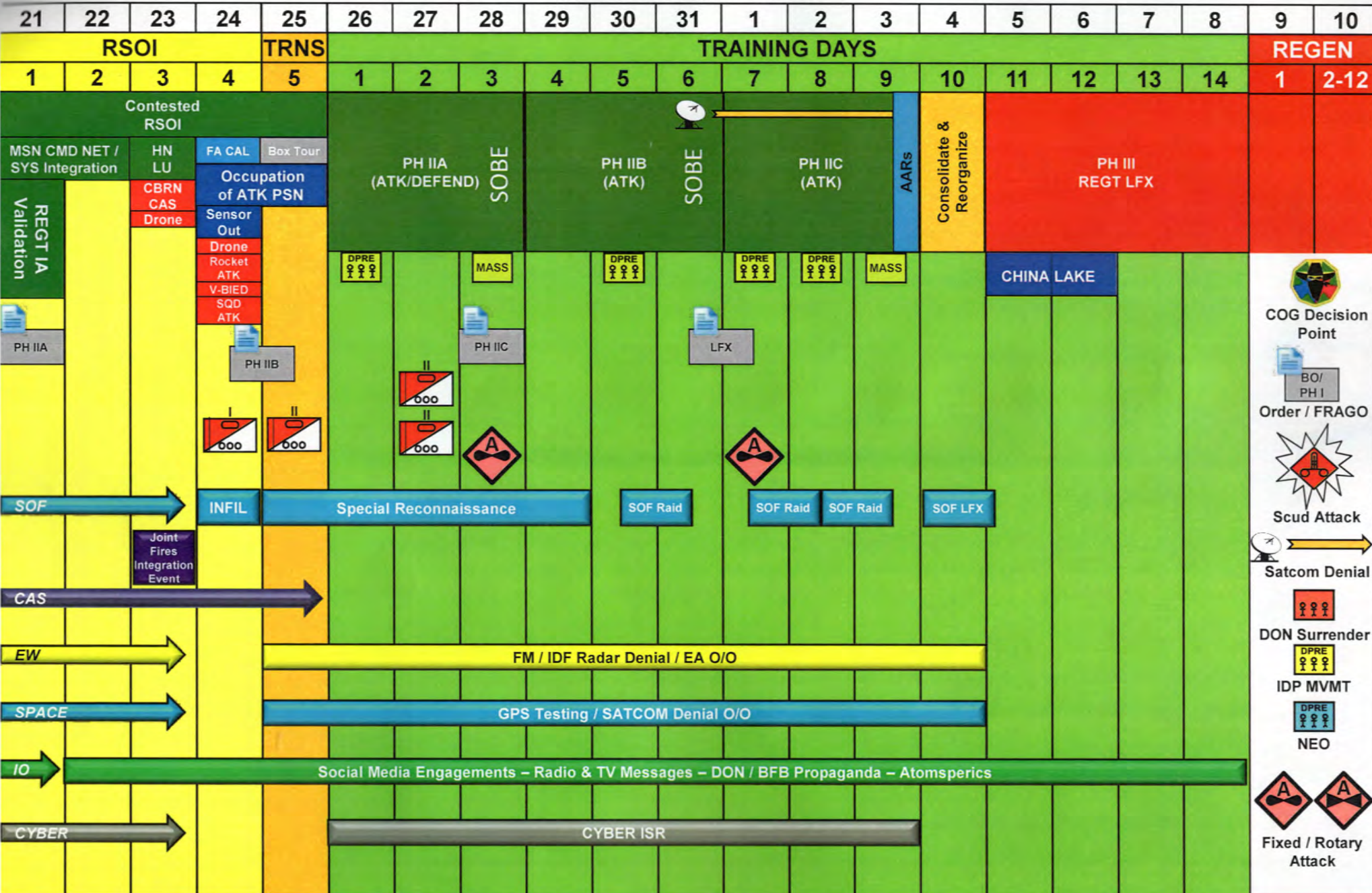

- COG Decision Point
- BO/PH I
- Order / FRAGO
- Scud Attack
- Satcom Denial
- DON Surrender
- IDP MVMT
- NEO
- Fixed / Rotary Attack

# OSC-S COA

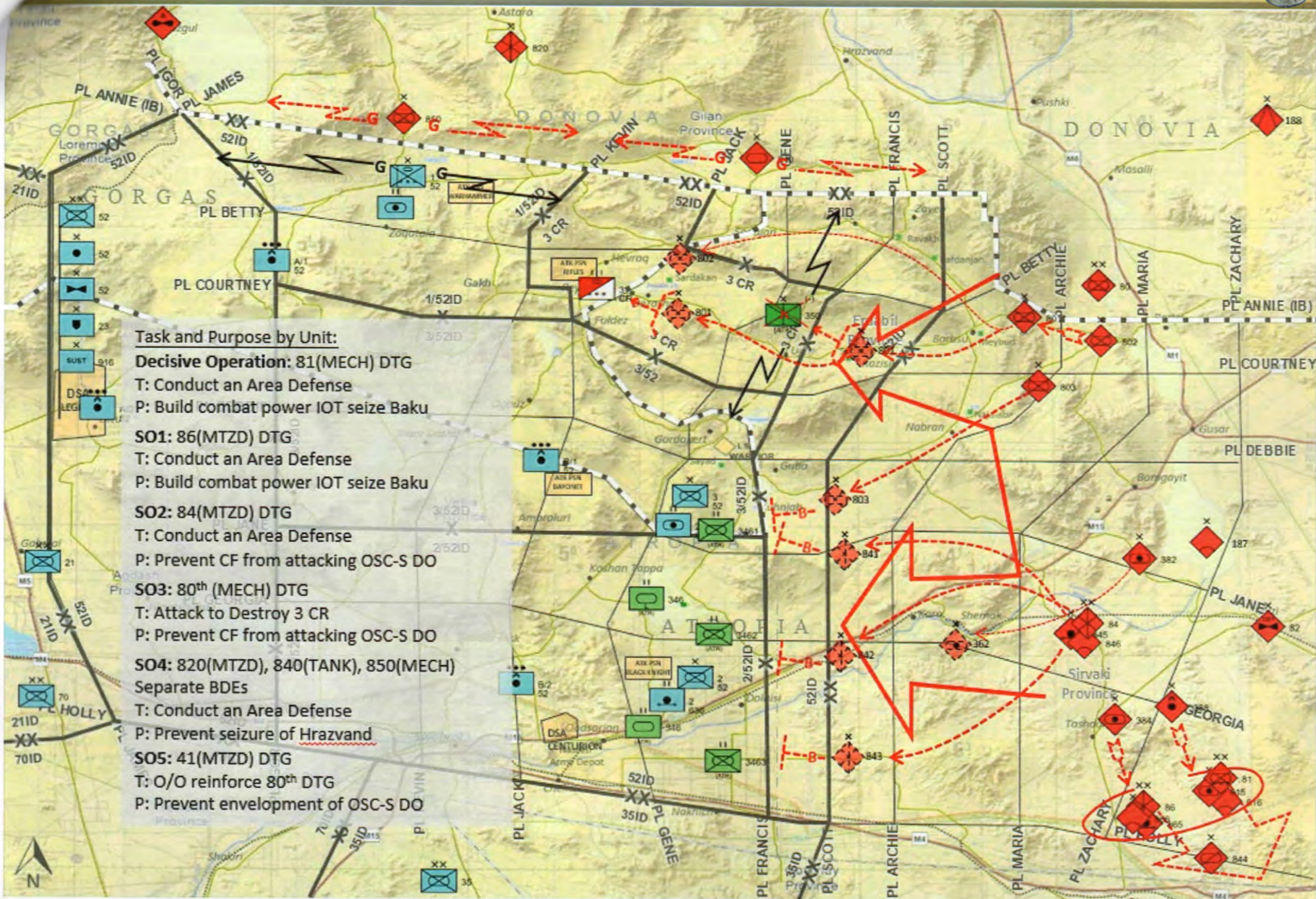



# PH IIA (TD1-3): ATK / DEF

## Critical Event MET

**ATK / DEF**

## REGT Subtasks

- REGT moves to ATK POS RSOI4-5 IOT execute attack
- CAV SQDN LDs (CRASH HILL) NET RSOI5 1800 IOT est. Security Zone
- Block Alpine Valley IVO PL JACK IOT prevent event envelopment NLT TD1
- ATK NLT 0600 TD 1 to seize OBJ RANGERS and OBJ ANGELS IOT deny enemy control of key terrain
- DEF NLT TD3 0600 along PL GENE (NO PEN LINE CRASH HILL) IOT protect the flank of the DIV DO

## SOF Actions

- Find, Fix, Neutralize JTF's HPTs IOT Degrade ENY cap. (Northern Corridor)
- Find, Fix, Neutralize JTF's HPTs IOT Degrade ENY cap. (Central Corridor)

## Adjacent Unit Tasks

- 350<sup>th</sup>: WP to Gardakert
- 1/52: GUARDING ALONG PL ANNIE (IB) WEST OF PL KEVIN
- 2/52: DEF WEST OF PL FRANCIS & SOUTH OF PL JANE
- 3/52: DEF WEST OF PL FRANCIS & NORTH OF PL JANE

## Enemy Actions

801(MECH) BTG(-) attacks to seize Crash Hill IOT defeat 3CR and retain key terrain.

## Other Key Events by Wf

DIV Enabled AASLT Window TD1-4

- DIVARTY SEAD
- CEMA
- SIGINT / FMV

Non-Lethal

TD1: IDP MVT across boarder

TD3: Protest in Dezashah

## Phase Ends

F: Prepares for future offensive Operations

E: 801(MECH) defeated

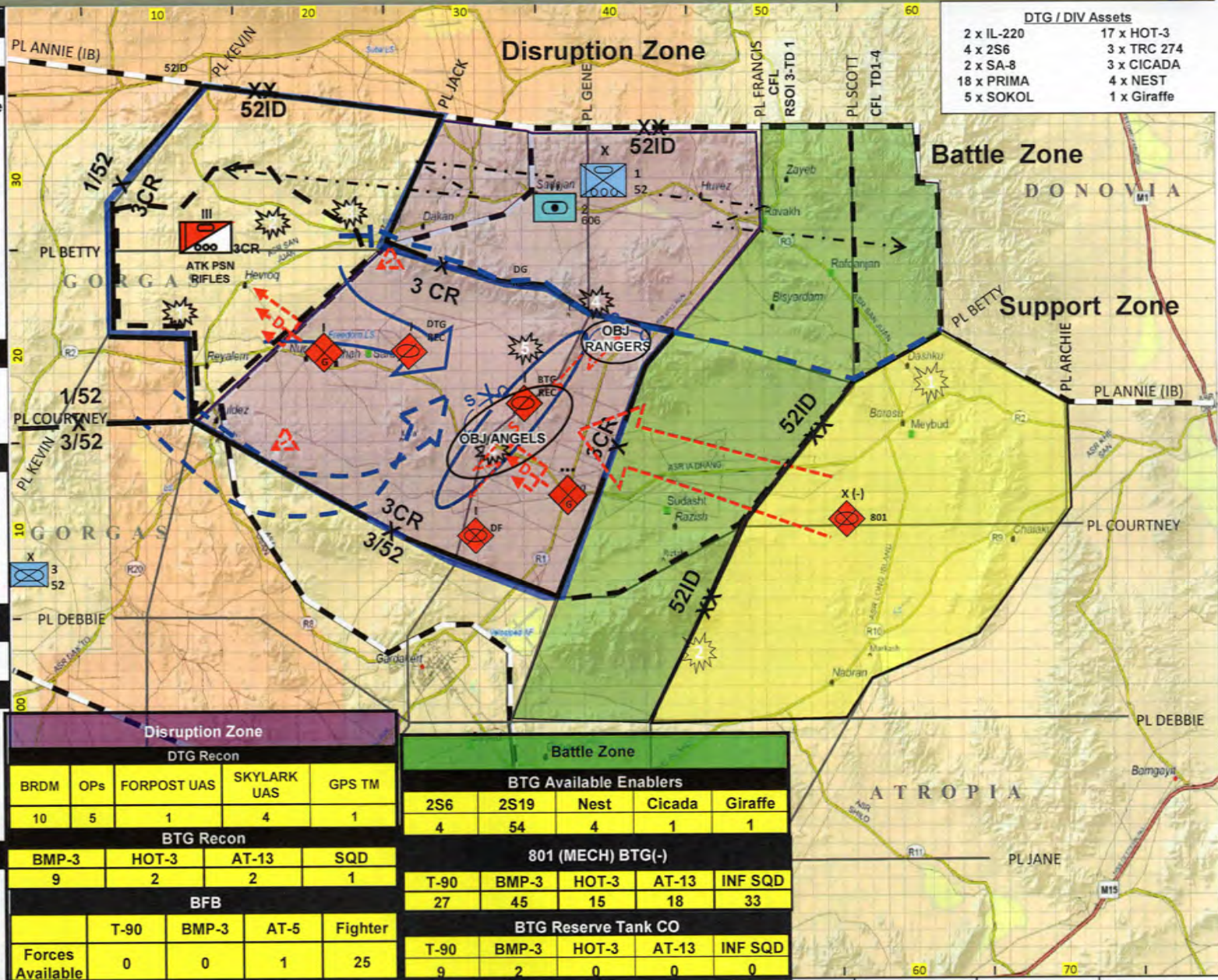

DTG / DIV Assets	
2 x IL-220	17 x HOT-3
4 x 2S6	3 x TRC 274
2 x SA-8	3 x CICADA
18 x PRIMA	4 x NEST
5 x SOKOL	1 x Giraffe

Disruption Zone				
DTG Recon				
BRDM	OPs	FORPOST UAS	SKYLARK UAS	GPS TM
10	5	1	4	1
BTG Recon				
BMP-3	HOT-3	AT-13	SQD	
9	2	2	1	
BFB				
Forces Available	T-90	BMP-3	AT-5	Fighter
0	0	1	25	

Battle Zone				
BTG Available Enablers				
2S6	2S19	Nest	Cicada	Giraffe
4	54	4	1	1
801 (MECH) BTG(-)				
T-90	BMP-3	HOT-3	AT-13	INF SQD
27	45	15	18	33
BTG Reserve Tank CO				
T-90	BMP-3	HOT-3	AT-13	INF SQD
9	2	0	0	0

OCT / NOV	24	25	26	27	28	29	30	31	1	2	3	4
TD	RSOI4	RSOI5	TD1	TD2	TD3	TD4	TD5	TD6	TD7	TD8	TD9	TD10
PH - OBJ			SEC-ZONE/ KT	EA DEV								AAR/C&R
			AASLT Window	MASS								

Train the Force

UNCLASSIFIED // FOUO // NO RELEASE TO RTU



# PH IIB (TD4-6): Attack



## Critical Event MET

### ATK

#### REGT Subtasks

Destroy remnants 802(MECH) / BFB on OBJ DODGERS (RAZISH) NLT 1200 TD6 IOT restore Atropian Governance of the Provincial Capital

#### SOF Actions

SOF RAID Nabran to neutralize jamming equipment IOT degrade ENY EW capability

#### Adjacent Unit Tasks

350th: Securing DSA WARRIOR  
 1/52: Guarding along PL ANNIE (IB) north of PL BETTY  
 2/52: C-ATK to destroy 840 TANK and 850 MECH BTG east of PL FRANCIS, south of PL JANE  
 3/52: C-ATK to destroy 820 MTZD BTG east of PL FRANCIS, north of PL JANE

#### Enemy Actions

802(MECH) BTG(-) Defends to Delay 3CR vic Central Corridor NLT TD5 (0600) to allow follow on forces to establish a Defense IVO Siberia.

#### Other Key Events by WIF

DIV Enabled ASSLT Window TD4-6

- DIVARTY SEAD
- CEMA
- SIGINT / FMV

#### DIV ATK AVN

TD5: SOF HAF IVO Nabran

#### Non-Lethal

TD5: IDP MVT OBJ DODGERS to FLOT  
 IDP MVT from FLOT to BSA  
 TD7: IDP to BSA  
 Protest at CSSB

#### Phase Ends

F: REGT hasty Defense along PL Scott rebuilding CBT PWR and preparing for future offensive operations.

E: Destruction of the 802(MECH)

DTG/DIV Assets	
2 x IL-220	17 x HOT-3
4 x 2S6	3 x WCCJ
2 x SA-8	3 x CICADA
18 x PRIMA	4 x NEST
5 x SOKOL	1 x Giraffe

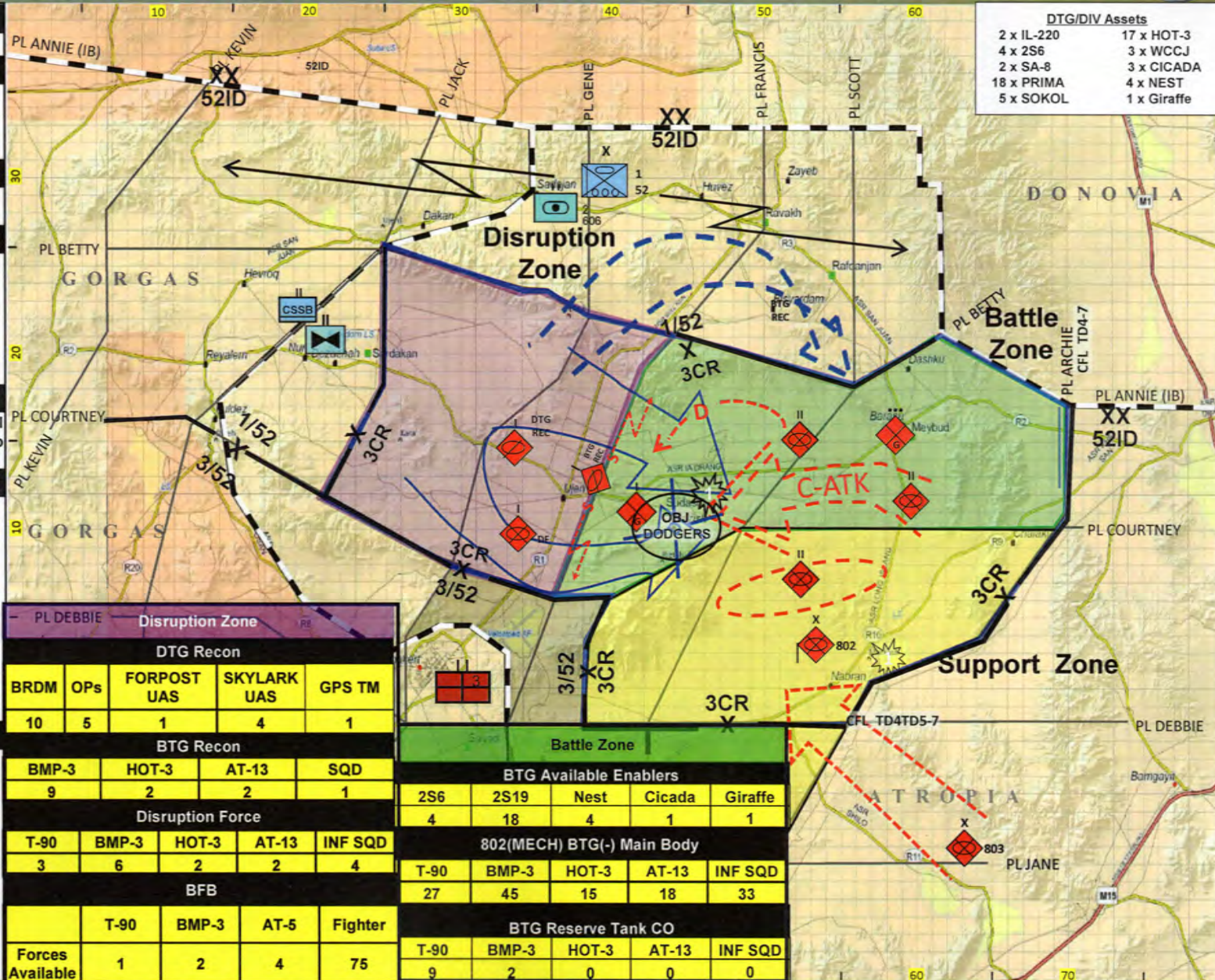

PL DEBBIE - Disruption Zone				
DTG Recon				
BRDM	OPs	FORPOST UAS	SKYLARK UAS	GPS TM
10	5	1	4	1
BTG Recon				
BMP-3	HOT-3	AT-13	SQD	
9	2	2	1	
Disruption Force				
T-90	BMP-3	HOT-3	AT-13	INF SQD
3	6	2	2	4
BFB				
	T-90	BMP-3	AT-5	Fighter
Forces Available	1	2	4	75

Battle Zone				
BTG Available Enablers				
2S6	2S19	Nest	Cicada	Giraffe
4	18	4	1	1
802(MECH) BTG(-) Main Body				
T-90	BMP-3	HOT-3	AT-13	INF SQD
27	45	15	18	33
BTG Reserve Tank CO				
T-90	BMP-3	HOT-3	AT-13	INF SQD
9	2	0	0	0

OCT / NOV	24	25	26	27	28	29	30	31	1	2	3	4
TD	RSOI4	RSOI5	TD1	TD2	TD3	TD4	TD5	TD6	TD7	TD8	TD9	TD10
PH - OBJ						ISOLATE RAZ		RAZ				
						AASLT Window						

Train the Force

UNCLASSIFIED // FOUO // NO RELEASE TO RTU

# PH IIC (TD7-9): Attack



## Critical Event MET

### Attack

#### REGT Subtasks

- Seize OBJ TIGERS (BARASU) NLT 2000 TD7 IOT deny enemy control of key population centers
- Destroy 803(MECH) BTG on OBJ INDIANS (JWFH) and Red Lake Pass to allow 52ID FOM NLT TD9 1000 IOT prevent the envelopment of the DIV DO
- O/O REGT seizes OBJ ROCKIES (WHALE) IOT prevent the bypass of the DIV DO

#### SOF Actions

- SOF RAID MCLB to interdict rail station IOT prevent ENY reserve trains
- SOF RAID Iron Wood to neutralize DON SPF C2 and BFB cadre IOT degrade irregular warfare cap.

#### Adjacent Unit Tasks

- 350th: Secures REGT Rear Area, PL JACK to PL DEBBIE
- 1/52: Guarding along PL ANNIE (IB) north of PL BETTY
- 2/52: Attacks to destroy 81st (MECH) DTG IVO PL JANE
- 3/52: Follow and supports 2/52

#### Enemy Actions

- 803(MECH) BTG(-) Defends to Delay 3CR from PL COURTNEY to PL DEBBIE to Allow 41(MTZD) DTG to enter AO

#### Other Key Events by WfF

- DIV Enabled ASSLT Window TD7-9
- DIVARTY SEAD
- CEMA
- SIGINT / FMV

#### Non-Lethal

- TD8: IDP MVT from NABRAN
- TD9: Protest at BEB

#### Phase Ends

- E: Destruction of 803(MECH)

- T: OBJ INDIANS and ASTROS seized

OCT / NOV	24	25	26	27	28	29	30	31	1	2	3	4
TD	RSOI4	RSOI5	TD1	TD2	TD3	TD4	TD5	TD6	TD7	TD8	TD9	TD10
PH - OBJ									BARASU	SEC ZONE/INT OBJ		AAR/C&R

### DTG/DIV Assets

2 x IL-220	17 x HOT-3
4 x 2S6	3 x WCCJ
2 x SA-8	3 x CICADA
18 x PRIMA	4 x NEST
5 x SOKOL	1 x Giraffe

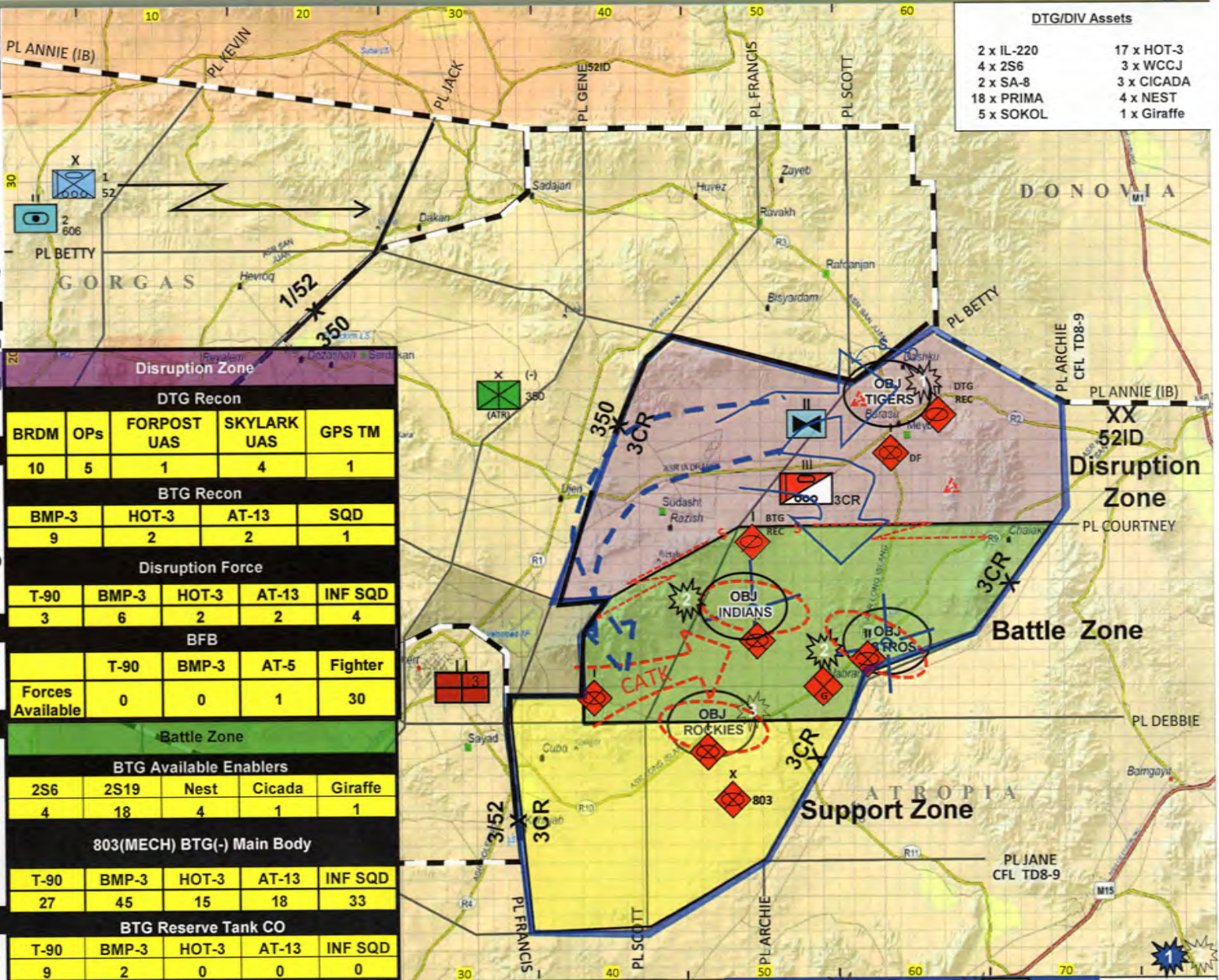

DTG Recon				
BRDM	OPs	FORPOST UAS	SKYLARK UAS	GPS TM
10	5	1	4	1
BTG Recon				
BMP-3	HOT-3	AT-13	SQD	
9	2	2	1	
Disruption Force				
T-90	BMP-3	HOT-3	AT-13	INF SQD
3	6	2	2	4
BFB				
Forces Available	T-90	BMP-3	AT-5	Fighter
0	0	1	30	
Battle Zone				
BTG Available Enablers				
2S6	2S19	Nest	Cicada	Giraffe
4	18	4	1	1
803(MECH) BTG(-) Main Body				
T-90	BMP-3	HOT-3	AT-13	INF SQD
27	45	15	18	33
BTG Reserve Tank CO				
T-90	BMP-3	HOT-3	AT-13	INF SQD
9	2	0	0	0

26	27	28	29	30	31	1	2	3	4
TD1	TD2	TD3	TD4	TD5	TD6	TD7	TD8	TD9	TD10
						DPRE	DPRE	MASS	
						BARASU	SEC ZONE/INT OBJ		AAR/C&R
						AASLT Window			

Train the Force

UNCLASSIFIED // FOUO // NO RELEASE TO RTU

# PH IIC (TD7-9): Attack



## Critical Event METCOG

### Attack

MEDEX COAs

4/3 CR,  
DF engagement  
At CTCP (Generator explosion)

1 or 2/3 CR,  
DF engagement  
At CTCP (Generator explosion)

FAS/3 CR, round explosion

RES/3 CR, maintenance accident

### Administrative Data

- MEDEX Soldiers participating will reside at the RUBA, tent TBD.
- Soldiers will not have MILES
- MEDEX (MRTC) POC, TBD
- MEDEX OPS GRP POC, GM 24
- Planning Factor Role II to Role III via HH-60

### Coordinating Instructions

- Pre-Ro Highlights no unit specifics
- Team 24 MEDEX Sync RSOI
- Detailed units briefed at CG Rollout TD6 GM 24 SYNC with MRTC
- TD7 Conditions check
- 1700 Update COG DP
- GM push to respective TM location
- TD8 Execution window 0800-1400

### COG Decision Points

- 1 TD8: Weather Call for HH-60 ground EVAC from Role II to Role III
- 2 Role 2 capacity and unit capability / proficiency
- 3 All burn patients simultaneously and at the same location? Multiple locations? Over a period of time?

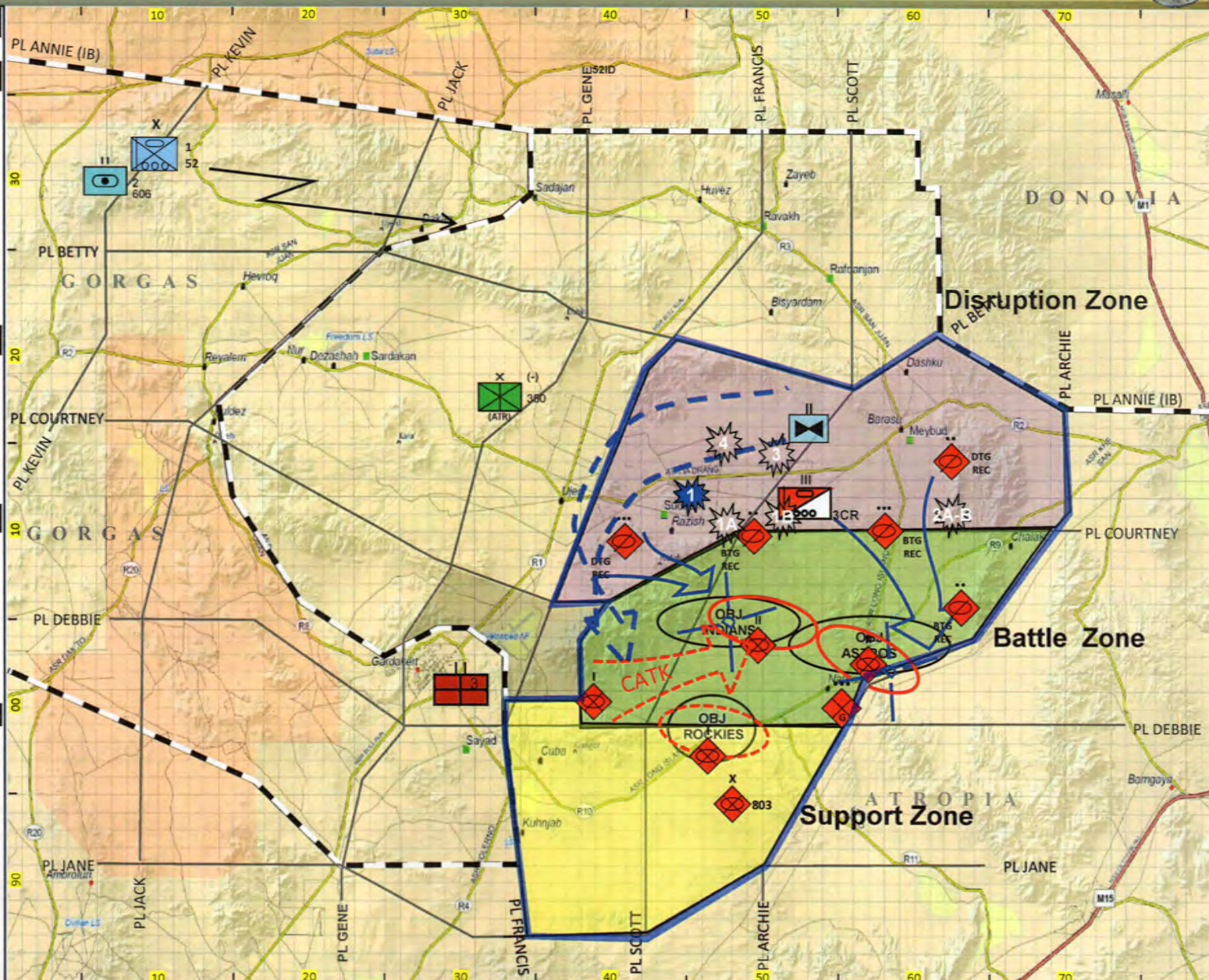

OCT / NOV	24	25	26	27	28	29	30	31	1	2	3	4
TD	RSOI4	RSOI5	TD1	TD2	TD3	TD4	TD5	1 TD6	2 TD7	3 TD8	TD9	TD10
PH - OBJ								GM 24 SYNC with MRTC	Con. Check COG DP	Execution 0800-1400		AAR/C&R

Train the Force

UNCLASSIFIED // FOUO // NO RELEASE TO RTU

## Key Events



- RSOI 1 – USCT introductory meetings with SOF
- RSOI 2 – POL/MIL, IDP working groups, BNFM Leader meeting, DON Invasion, USG meetings with RTU
- RSOI 3 – Joint press conference, civilian chemical casualties at RUBA Essential Services WG, 350<sup>th</sup> O&I, IDP WG
- RSOI 4 – Large protest, DC backbrief to 52ID
- RSOI 5 – 2<sup>nd</sup> Large Protest
- TD 1 – IDPs from Dezashah across Gorgas border (40)
- TD 2 – Projected FHA in Dezashah, Protest at BSB
- TD 3 – Protest in Dezashah
- TD 4 – SOBE
- TD 5 – IDPs from Razish to FLOT and from FLOT to BSA (75)
- TD 7 – IDPs to BSB (35) and Protesters at CSSB. O/O – 75 IDPs from Nabran to FLOT.
- TD 8 – Projected FHA in Razish, Protest at BSB
- TD 9 – Protest at BEB (40)



## **TOWN INFO:**

GUBA, (11S NU 354970), is a town located in Yangin District in Erdabil Province, Atropia. The current location occupies a slight depression around some high ground and was selected for its proximity to local water sources. The terrain surrounding the town is open sparsely vegetated desert. The Tiefert mountain range is roughly seven kilometers northeast of Guba. The cave known as Gangor is approximately two kilometers northeast of Guba. The town consists of approximately 30 large, primarily residential, structures (10 of which are two-story) arrayed in a rectangular pattern. There is no identified subsurface. The flat roofs of the large structures allow for some operations on the super-surface top. Each structure typically is a single family dwelling. There is a religious shrine in the town. No railroads exist in the vicinity of Guba. A dry lake bed lies approximately 2 km south of Guba. During heavy rains this lake bed will fill with water. Dry lake beds should be considered off limits as they would not be suitable for drop/landing/pickup zones for delivery and movement of FHA supplies and DCs. No airports, airfield, or marked landing zones exist in the vicinity of Guba. There is an inactive oil pipeline located roughly five kilometers southeast of Guba.

## **MEDIA:**

There is one (1) radio stations and three (3) television networks whose broadcasts are receivable in Guba. Government control of existing land line service forces most people in the province to resort to more expensive cell phone use. The Brotherhood, a neutral Atropian paper still available in the town. There are journalists operating throughout the province, both HN and Independent Press.

## **SERVICES:**

Guba maintains a small clinic. Numbers of doctors and nurses is unknown. Supplies and equipment are severely lacking. There is a small police force, less than 10 officers. Atropian Army and National Police may also be present. There is no court system in place. There is a branch of the government-operated Atropia Central Bank in Guba. Guba has a school but it is not known if there is a teacher or if the school is still in use.

## **UTILITIES:**

Power is provided by a centrally located generator possibly of 50kw strength. Waste management is an ongoing issue in Guba. Sewage system consists of only chemical latrines in the town that is serviced by a private contractor. Water used for washing and personal hygiene is typically dumped outside the residential buildings. Town has no plumbing or water treatment systems. Trash is typically burned and dumped in larger areas outside town.

## **PRODUCTION/ECONOMY:**

The majority of agricultural output is for family subsistence and market place vending of food products. The Atropian government and family owned businesses are the top employers in the town. No manufacturing exists at this time. Black market activities exist.

## **BASIC NEEDS:**

Most food products are purchased from or brought in from the city of Gardakert. The town has a well.

## **ETHNIC AND POLITICAL BREAKDOWN:**

The Lezgin hold the positions of mayor and police chief. The population of Guba consist of the following: Lezgin. 80%. Atropian. 20%.

## **TOWN OFFICIALS:**

Town Mayor. Azhar Turay, a Lezgin.

Police Chief. Yasin Hossain, an anti-Bilasubar Lezgin.



## **TOWN INFO:**

Dezashah, (11S NV216195), is a small town in Samal District. There are no identified sub-surface tunnels or structures in Dezashah, but 6 km southeast of the town is the Kara cave (11S NV260151) which was a Borax mine. There are approximately 35 large structures (seventeen being 2-story) along with 20 smaller structures in the town arrayed in an irregular pattern going north to south of the main line of communication, Route R2. Dezashah is mostly residential with a few commercial facilities. There is a religious shrine in the town. No railroads exist in the vicinity of Dezashah. A dry lake-bed is located approximately 1 km to the northwest of the town and water can accumulate there after heavy rain fall. A 1,000 meter airstrip is located directly outside the northern part of the town. This facility could be used for DC and FHA operations.

## **MEDIA:**

Dezashah is within the listening/viewing range of three (3) TV and two (2) radio stations. Government control of existing land line service forces most people in the province to resort to more expensive cell phone use. The Brotherhood, a neutral Atropian paper still available in the town. There are journalists operating throughout the province, both HN and Independent Press.

## **SERVICES:**

Dezashah maintains a small clinic with a doctor and two nurses. The clinic is severely lacking medical equipment and supplies. Due to the recent military operations by the Atropia Government elements of the Atropian army and National Police are in the town. There are no court system in place. The town has 4 personnel that make up the firefighting team. Equipment and vehicles status is unknown. The town lacks any paramedic capability. There is a branch of the Atropia Central Bank located in Dezashah. The one school in Dezashah is in a bad state of disrepair. It is believed that there are three teachers within Dezashah.

## **UTILITIES:**

Electrical power provided by a centrally located generator possibly of the 50kw range; some shortages of fuel and electricity. Sewage system consists of only chemical latrines within the town which is serviced by a private contractor hired by the provincial government. Water used for washing and personal hygiene is typically dumped outside the residential buildings. Town has no functioning plumbing or water treatment systems. Trash is usually disposed of locally or burned.

## **PRODUCTION/ECONOMY:**

There is limited small scale farming in the area consisting mainly of poultry and subsistence farming. A number of small family operated businesses exist but they typically employ only a few people and usually only within the immediate family; these businesses are typically food-stands, repair businesses, and small general stores. Dezashah's economy like many of the population centers in Erdabil Province has been neglected for years by the Atropia Government causing some of the inhabitants to do business with the criminal network. No known manufacturing exists within Dezashah. There are several black market operations in Dezashah. Drugs and weapons trafficking are prevalent due to the close proximity to the International Border. Some criminal elements are directly linked to the Bilasuvar Freedom Brigade (BFB) activity.

## **BASIC NEEDS:**

Food items come from Donovia by local travelers and merchants.

The town does have a well. The people of Dezashah need water; the well has been contaminated for the past few months and the people have been relying on shipments of bottled water; now that the war has started, those shipments have stopped and the people are running out of potable water.

## **ETHNIC AND POPULATION BREAKDOWN:**

Atropia has appointed government officials as mayor and police chief of Dezashah.

The population of Dezashah consists of the following: Bilasuvar – 90%. Atropian – 10%. The town population is between 1,300 and 1,500 people.

The Bilasuvar in Dezashah are sympathetic to the BFB's Grievances, but have not historically supported DON/BFB, but now being swayed by the BFB's narrative and influence.

## **TOWN OFFICIALS:**

Town Mayor. Fakhaddin Mousa, ethnic Atropian and a pro-Atropian official. Police Chief. Muhammad Bangura, ethnic Atropian and a pro-Atropian official.

# Kuhnjab



## **TOWN INFO:**

KUHNJAB, IVO (11S NU341929), is a small town located in Vetlia Province. It lies approximately four kilometers south of the town of Guba, Erdabil Province. There are two dozen buildings. These appear to be single-family dwellings. The land around it is open desert with sparse vegetation. No railroads exist in the vicinity of Kuhnjab. No waterways or canals exist in the vicinity of Kuhnjab. There are no aircraft facilities near Kuhnjab.

## **MEDIA:**

Kuhnjab is within the listening/viewing range of three (3) TV and one (1) radio stations. Government control of existing land line service forces most people in the province to resort to more expensive cell phone use. No schools identified. There is a Lezgin paper "Hurriyet Habar" which is Pro-Atropian. There is a moderate Bilasuvar newspaper called "Etihad" which is Pro-Atropian. The "Umut Gazette is a Bilasuvar propaganda publication that is funded by Donovia and circulated by the BNFM. There is also Independent Press throughout the country.

## **SERVICES:**

There are no services available in the town.

## **PRODUCTION/ECONOMY:**

There is small family farming. No other means of food production are present. There is no commercial production in the town.

## **BASIC NEEDS:**

No visible sign of a well within the town limits.  
Limited locally produced farm products.

## **ETHNIC AND POPULATION BREAKDOWN:**

The population of Kuhnjab consists of the following:

Lezgin – 85%

Atropian – 15%

There is between 100 and 200 people living in the town.

## **TOWN OFFICIALS:**

Town Mayor. Purev Matar is an ethnic Atropian.

Police Chief. Chongis Sunit is an ethnic Lezgin.

Influential Leaders. Enkh Obeid, Religious Leader



## **TOWN INFO:**

NABRAN, (11S NV543011) is located approximately 11 kilometers southeast of Razish. The town consists of approximately 58 structures (thirteen of which are two-story) and 10 smaller structures arrayed in an irregular pattern that straddles both sides of Route R10. Nabran is a mixture of residential and small commercial facilities. Each structure typically is a single family dwelling or business, but some extended family may reside within each structure. Some of these structures could possibly be used for housing Dislocated Civilians or serve as distribution points for FHA supplies. There is a religious shrine in the town. There are no railroads exist in the vicinity of Nabran although there is a 1,000-meter unimproved airstrip is located approximately 5km northeast of the town. Aerial footage shows damage to the airstrip. This facility could be used for DC and FHA operations. There is an inactive pipeline located roughly six kilometers west of Nabran.

## **MEDIA:**

There are one radio station and three (3) television networks whose broadcasts are receivable in Nabran. Government control of existing land line service forces most people in the province to resort to more expensive cell phone use. The Brotherhood, a neutral Atropian paper still available in the town. There are journalists operating throughout the province, both HN and Independent Press.

## **SERVICES:**

There is a clinic in Nabran. Staff numbers and amount of supplies are unknown at this time. There is a small police force made up of Lezgins. There are elements of the Atropian army and National Police in the town. There are no Courts/Court System, Fire/Paramedic Services. There is a branch of the Atropia Central Bank. Nabran has a small functioning school which provides for the education of all of the towns' children. The number of students and teachers is unknown at this time. The school could be used as a temporary shelter for DCs and as a distribution point for FHA supplies.

## **UTILITIES:**

Electrical power is provided by a centrally located generator possibly of the 50kw range and there is a shortage of fuel throughout the year. Sewage system consists of only chemical latrines within the town which is serviced by a private contractor hired by the provincial government. Water used for washing and personal hygiene is typically dumped outside the residential buildings. Town has no functioning plumbing or water treatment systems. Trash is usually disposed of locally or burned.

## **PRODUCTION/ECONOMY:**

There is limited small scale farming in the area consisting mainly of poultry farming and subsistence farming. The top employer is the local government. The government runs the school, clinic, dentist, gas station, police station, and a bank. Several small family-operated businesses do exist. There is no manufacturing industry in Nabran. There are several black market operations in Nabran. These criminal endeavors appear to be a hub for local criminal/insurgent smuggling efforts operating in the Yangin district. The criminal activities are believed to be centered on weapons and drug trafficking.

## **BASIC NEEDS:**

A few poultry and vegetable farmers are located in the vicinity of the town. These farmers sell their products at local vending shops although the majority of their crops are for family subsistence. The drought has caused enormous issues for the local farming industry. Shortages of some food stocks exist and are being exacerbated due to the presence of DCs. The town has a well but needs additional water resources.

## **ETHNIC AND POPULATION BREAKDOWN:**

The Lezgin hold the positions of mayor and police chief. The population of Nabran consists of the following: Lezgin – 66%. Atropian – 34%. The majority of Lezgins are suspicious of the Atropian government. They feel that they have been historically disenfranchised and there is a popular desire for some sort of autonomy. The people of Nabran will tend to support the RTU unless there are negative incidents. The majority of ethnic Atropians in Nabran are supportive of the Atropian government; they have benefited the most from recent economic developments, to include the oil industry. There are chronic shortages of food, water, and medicine, but no acute shortages of any specific resource.

## **TOWN OFFICIALS:**

Town Mayor. Naranbaatar Angarag is an ethnic Lezgin. Police Chief. Altan Lovei is an ethnic Lezgin. Influential Leaders. Azaad Yaqub Bazar, Lezgin Now! Leader and café owner.





## TOWN INFO:

RAZISH, (11S NV439101), is the capital and largest town in Yangin District of Erdabil Province. It is located approximately 3 kilometers south of the main east-west line of communication R2 (Route 2) and approximately 8 kilometers east of Ujen. A tunnel complex exists under Razish based on the remnants of a non-functional sewer and water pipe system. These tunnels most likely are not used anymore. Riztab Abandoned Mine: It is located approximately 1.5 kilometers to the southwest of Razish and is the remnant of a government-operated mine which ceased functioning at the end of the UDR. Most of the dwellings house a single family but a number of them may house an extended family. There is a prison located in Razish. The US Consulate is located in Razish. No railroads exist in the vicinity of Razish.

## MEDIA:

Razish is within the listening range of two (2) radio stations. Razish is within the viewing range of three (3) TV stations. Government control of existing land line service forces most people in the province to resort to more expensive cell phone use. The Brotherhood, a neutral Atropian paper still available in the town. There are journalists operating throughout the province, both HN and Independent Press.

## SERVICES:

There is one hospital located in Razish. The status of this hospital is unknown. The number of doctors and nurses is unknown at this time. Due to recent military operations by the Atropian Government, elements of the Atropian army and National Police are in the town. There is no court system. Razish has a small contingent of fire fighters but no paramedic service. There is a branch of the Atropia Central Bank. The number of operational schools, students and teachers is unknown. There is a university in Razish but it has been shut down.

## UTILITIES:

Power upgraded with transformers. Some generators still in operation. Electrical power provided by a centrally located generators usually of the 50kw range of which there may be more than one given the size of Razish; some shortages of fuel and electricity. Sewage system consists of only chemical latrines that are serviced by a private contractor hired by the provincial government. There is a water treatment plant. Water used for washing and personal hygiene is typically dumped outside the residential buildings. There are no working plumbing or water treatment systems. Trash is usually disposed of locally or burned. **There are CCTV cameras in the town.**

## PRODUCTION/ECONOMY:

The majority of agricultural output is for family subsistence and market place vending of food products. The single top employer had been the government. The government funded the schools, police station, hospital, bank, and fire station but has been neglected due to budget cuts. A number of small family operated businesses (mostly poultry farming and service type) exist, but they typically employ only a few people and usually only within the immediate family. With the closure of the mine, no large scale manufacturing exists any longer. There are still a few family-style businesses such as the carpenter's shop, brick-maker, and automotive repair shop. There is a well-established black market operating in the town involving illicit goods and the trafficking of drugs. Medical supplies are a hot commodity on the black market. It is likely there is a "crime lord" operating in Razish.

## BASIC NEEDS:

A number of farmers sell a portion of their crops to the local population at food stands operated in the market square. Additionally, several local eateries purchase food from farmers around the area. Local wells supply Razish and the surrounding area with water. The town is low on diesel fuel for their generators and medical supplies (blood, plasma, IV solution, antibiotics) as the BFB have stolen these resources.

## ETHNIC AND POPULATION BREAKDOWN:

Atropia has emplaced appointed government officials in Razish. The population of Razish consists of the following: Bilasuvar - 34%. Atropian - 33%. Lezgin - 33%. The town population is between 5,000 and 5,500 people. The ethnic Atropians in Razish support the Atropian government and U.S. Forces. The Bilasuvar are less supportive of the BFB/Donovians than Ujen Bilasuvar and can be convinced to support the U.S. and Atropia. The Lezgins will support U.S. forces if the RTU can convince them to do so.

## TOWN OFFICIALS:

Town Mayor. Yusuf Shabazz, ethnic Atropian and a pro-Atropian official. Police Chief. Rahib Pirani, ethnic Atropian and a pro-Atropian official.



## **TOWN INFO:**

UJEN, (11S NV368119), is located in Samal District approximately 8 kilometers west of Razish, along R1 as it intersects with R2. The town has the key bus terminal for Erdebil Province in that it is the focal point for all buses going east/ west and those leaving the province going to either Donovia or neighboring provinces. Ujen consists of approximately 270 structures. The older section of the town is surrounded by newer constructed buildings loosely arrayed in a radial pattern around the highways' intersection. The town has numerous multi-story buildings particularly along the main avenues but has no identified subsurface. Each structure typically is a single family dwelling or business, but some extended family may reside within each structure. In multi-story buildings, a business usually occupies the ground floor while the family residence is located on the second floor. No railroads exist in the vicinity of Ujen.

## **MEDIA:**

Ujen is within the listening/viewing range of three (3) TV and two (2) radio stations. Government control of existing land line service forces most people in the province to resort to more expensive cell phone use. The Brotherhood, a neutral Atropian paper still available in the town. There are journalists operating throughout the province, both HN and Independent Press.

## **SERVICES:**

There is one clinic located in the Government/Professional district. The number of doctors and nurses is unknown and medical equipment is lacking. The Atropian National Police are now the main law enforcement apparatus and there are no courts. Ujen has one fire station. There are no Paramedics. There is a branch of the Atropia Central Bank. Public transportation assets that exist in Ujen are limited in quantity.

## **UTILITIES:**

Power upgraded with transformers. Some generators still in operation. Electrical power is provided by a centrally located generator of at least 50kw strength that is vulnerable to attack. Fuel is limited at times during the year. Sewage system consists of only chemical latrines. Water used for washing and personal hygiene is typically dumped outside the residential buildings. There are some provincial level trash collection efforts in the town.

## **PRODUCTION/ECONOMY:**

The majority of agricultural output is for family subsistence and market place vending of food products. 5 Many individuals in Ujen are self-employed, working as farmers or in the service industry. There are a small number of businesses which cater to the local farming industry. The Atropian government ran the four schools, one police station, one hospital, one bank, and one fire station. The vast majority of businesses, however, are small family-operated. The closure of the local borax mine has caused a void in local employment. There are no factories or larger manufacturing-style businesses functioning in Ujen at this time. There are several black market operations in Ujen dealing with everything from smuggling opium to black market fuel to human trafficking. These criminal endeavors appear to be small in nature and localized, but may also be connected to the BFB.

## **BASIC NEEDS:**

No shortages of food supplies. The town has a fresh produce and food market between what is locally produced and goods brought in from outside the province. A few local farmers are located in the vicinity of the town. These farmers sell small quantities of their produce and grains at vender stalls located in the Ujen town market. Limited water supply is used mainly for agricultural purposes.

## **ETHNIC AND POPULATION BREAKDOWN:**

The Atropian Government has appointed government officials as mayor and police chief of Ujen. The population of Ujen consists of the following: Bilasuvur – 66%. Atropian – 34%. The town population, approximately 2,500 individuals. Most Bilasuvur in Ujen support the BFB, Donovia and Arash Golzar. The BFB will abuse and persecute non-Bilasuvur. U.S. Forces will have to work hard to convince Ujen Bilasuvur to support U.S. and Atropia.

## **TOWN OFFICIALS:**

Town Mayor. Namvar Ishak, ethnic Atropian and a pro-Atropian official. Police Chief. Artoghul Jabara, ethnic Atropian and a pro-Atropian official.



## **TOWN INFO:**

BARASU, (11S NV592159), is a town located approximately 17km east by northeast of Razish near the intersection of Route R3 and R2. No identified sub-surface tunnels or structures exist. The terrain surrounding the town is sparsely open vegetated desert. There is a mountain range approximately 4km to the east that runs north-south along the border of Erdabil Province, Atropia and Donovia. These mountains probably contain smuggling routes between the two countries. There are approximately 35 structures (seven being 2-story) in the town arrayed in a linear pattern corresponding along the lines of communication centered on a road intersection. Barasu is mostly residential with a few commercial facilities. Each structure typically is a single family dwelling or business, but some extended family may reside within each structure. No railroads exist in the vicinity of Barasu. No waterways or canals exist in the vicinity of Barasu. No airports, airfield, or marked landing zones exist in the vicinity of Barasu. There is an inactive pipeline and oil well located near Barasu.

## **MEDIA:**

Barasu is within the listening/viewing range of three (3) TV and two (2) radio stations. Government control of existing land line service forces most people in the province to resort to more expensive cell phone use. The Brotherhood, a neutral Atropian paper still available in the town. There are journalists operating throughout the province, both HN and Independent Press.

## **SERVICES:**

There are no medical facilities. The Atropian National Police provide security and there is no court system in the town. There is no banking or financial system in town. There is a school in Barasu. The number of students and teachers are unknown at this time.

## **UTILITIES:**

Electrical power is provided by a centrally located generator possibly of the 50kw range. There are some shortages of fuel and in turn electricity. Sewage system consists of only chemical latrines in the town that is serviced by a private contractor. Water used for washing and personal hygiene is typically dumped outside the residential buildings. Town has no plumbing or water treatment systems.

## **PRODUCTION/ECONOMY:**

The majority of agricultural output is for family subsistence and market place vending of food products. Family owned businesses. No manufacturing exists at this time. There may be some black market selling of goods smuggled into the province by criminal organizations in the province.

## **BASIC NEEDS:**

Limited food, but a number of farmers sell a portion of their crops to the local population at food stands operated throughout the town. Local water supply is provided by a functioning well.

## **ETHNIC AND POPULATION BREAKDOWN:**

The Atropian Government has appointed government officials as mayor and police chief of Barasu. The population of Barasu consists of the following: Bilasuvar – 90%. Atropian – 10%. Population is believed to be around 500. Bilasuvar in Barasu are sympathetic to the BFB's cause and grievances, but they do not want a war and can be swayed to support the U.S. forces and the Atropian government if the RTU can convince them to do so. There are a large number of CCHF cases in Barasu; the town does not have a medical clinic and needs help with CCHF.

## **TOWN OFFICIALS:**

Town Mayor. Uzeyir Javid, ethnic Atropian. Police Chief. Yafi Qumi, an ethnic Atropian. Religious Leader: Yul Bazar, an ethnic Atropian



## PROCOB TEAM

### Atropian Government

Provincial Governor – Luft Mohuiddin

Public Affairs – Omar Eric

### Atropian Security Forces

Provincial Police Chief – COL Khoyski

350<sup>th</sup> DCO – COL Ladov

### Key Civilian Personalities

Lezgin Now! – Asaad Yaqub Bazar

Media Owner – Aliya Torabi

Former Governor – Arash Golzar

### NGO / IGO

All Hands Atropia – Samira Malfouf

2x UN HA Delivery Specialists

## INTERAGENCY TEAM

### U.S. Country Team

Deputy Chief of Mission – Scott McGehee

Public Diplomacy Officer – Evan Reade

Regional Affairs Chief – Michael Workman

SDO/DATT – Emily Thomas

USAID – Tim Ecklund



# BAKU · ATROPIA

## INTERAGENCY US EMBASSY FORWARD TEAM



**Deputy Chief of  
Mission (DCM)  
Scott McGehee**



**Public  
Diplomacy  
(PDO)  
David Barne**



**Regional Affairs  
Philip Perez**



**USAID  
Michael Maxey**



**UN  
Humanitarian  
Coordinator  
Tim Ecklund**

# Large Protest (RSOI 4)



**PT**  
**ask:** Protest/disrupt US forces in Atropia  
**o:** Undermine the credibility of US Forces by showing combat forces are incapable of maintaining security, even unarmed protesters. Draw favorable media attention to FM.

War residents from Gorgas approach LSA WARRIOR and protest outside the entry control point. The people in the US presence in Atropia and the possibility of the ending Donovia. They accuse the US of trying to provoke a war into a war and using Donovia's support for the war as an excuse to invade Donovia. **The protesters attack an undercover Gorgan police officer in the crowd. The protesters attack him, take his pistol, and shoot him (serious but not fatal injury) if the RTU does not intervene.** The shooter does not directly threaten U.S. forces with the pistol. The Gardakert mayor and police chief arrive 10m later. The crowd disperses if the RTU has a successful engagement with the

The protesters will be disruptive but will not directly threaten the RTU.

### REQUIREMENTS

- Bilasuvar Protesters
- Gardakert Mayor & Police Chief
- Gorgas Police Officers
- Pistol
- Age and squibs for officer and shooter
- Horn/speakers

### SCHEME OF MANEUVER

- Protesters arrive at Gate 1
- Media arrives at the gate with the protesters.
- Protesters will shout anti-U.S. slogans and refuse to leave.
- The protesters will discover and attack the undercover officer; they will shoot him (non-fatal injury) if the RTU does not intervene (if necessary)
- Gardakert Mayor, Police Chief, and three Atropian police officers will arrive to attempt to speak with the crowd and the soldiers at the gate.

### TIMELINE

- 1- Brief Role Players at the Role Player barracks
- 2- Begin movement from Role Player barracks
- 3- Protesters arrive at Gate 1; media follows soon after
- 4- Protesters attack undercover officer
- 5- Gardakert mayor and police chief arrive

1 ECP 1 (Protest location)

Ethnicity	Total	Role Player	Black Horse	Police	Mayor
Bilasuvar	75	75	0	3	1



OCT	22	23	24	25	26	27	28
TD	RSOI 2	RSOI 3	RSOI 4	RSOI 5	TD 1	TD 2	TD 3
PH-OBJ			MASS				

# Large Protest II (RSOI 5)



## CONCEPT

**COB Task:** Protest/disrupt US forces in Atropia  
**Purpose:** The protesters are seeking assistance from US Forces in finding and accounting for family members who were unable to escape Atropia prior to the Donovanian invasion.

Atropian citizens who are now refugees in Gorgas arrive at ECP 1 and plead with US Forces for assistance. The demonstrators are seeking assistance with finding and accounting for family members who were unable to escape Atropia prior to the Donovanian invasion. The demonstrators are seeking a commitment from the BCT commander to account for their friends and family members. If the BCT makes promises to the demonstrators, but does not deliver on these promises, the result is negative press coverage and increased BFB violence throughout the rotation. The desired action from the RTU is to call the Gorgas police to disperse the demonstrators.

**ROE:** The protesters will be disruptive but will not threaten the RTU.

## REQUIREMENTS

- 75x Atropians
- Gardakert Mayor & Police Chief
- Bullhorn/speakers

## SCHEME OF MANEUVER

- Protesters arrive at Gate 1
- Protesters will refuse to leave and plead with US Forces to help account for friends and family who were unable to escape Atropia..
- Gorgas Police and Gardakert Mayor will attempt to break up the demonstration and assuage the demonstrators.

## TIMELINE

- 0800- Brief Role Players at the Role Player barracks
- 0830- Begin movement from Role Player barracks
- 0900- Protesters arrive at Gate 1; media follows
- 0945- Gardakert mayor and police chief arrive.

1 ECP 1 (Protest location)



Ethnicity	Total	Role Player	Black Horse	Police	Mayor
Atropian	75	75	0	3	1

OCT	22	23	24	25	26	27	28
TD	RSOI 2	RSOI 3	RSOI 4	RSOI 5	TD 1	TD 2	TD 3
PH-OBJ				MASS			

# Protests (TD 3, 6, 7, 9)



## CONCEPT

**COB Task:** Protest/disrupt US forces in Atropia

**Purpose:** Undermine the credibility of US Forces by showing that combat forces are incapable of maintaining security, even from unarmed protesters. Draw favorable media attention to the BNF.

Bilasuar residents are angry that conditions have deteriorated since US forces entered Atropia. Protesters arrive at the designated protest location with signs and a bullhorn and complain bitterly about US involvement in Atropian affairs. They blame Donovia's invasion as a result of US provocation. They also attribute the lack of food, water, and medical supplies due to US forces blocking roads.

There are four conditions which would cause the protests to disperse: (1) RTU engages protesters. (2) Police/Mayor are called in to help. (3) RTU leadership speaks with protest leaders to address their concerns for food, water, and medical supplies. (4) RTU leaves the area. Protesters will not attempt to harm the RTU but will attempt to go around inadequate security measures – such as a single strand of concertina. The protesters do not have injuries or weapons.

**ROE:** The protesters will be disruptive but will not directly threaten the RTU. Protesters will carry printed enemy propaganda, leadership may have intel products.

## REQUIREMENTS

- xx Bilasuar Protesters
- Town Mayor & Police Chief
- 3x Atropian Police Officers
- Bullhorn and protest signs
- Media on the battlefield

## SCHEME OF MANEUVER

1. Protesters will arrive at protest location.
2. Media arrives at protest location.
3. Protesters will chant anti-U.S. slogans and refuse to leave.
4. Protests will continue until time expires or end conditions met.
5. Town Mayor, Police Chief, and three Atropian police officers will arrive to attempt to speak with the crowd and the soldiers if called by the RTU.

## TIMELINE

- 0700 Brief Role players
- 0730 – Begin movement to protest
- 0800 – UTC Protest

### Protest Locations Based on RTU location:

- TD 2: 75 at BSB (Goldminer)
- TD 3: 100 in Dezashah
- TD 7: 35 at CSSB (Goldminer)
- TD 8: 75 at BSB (Goldminer)
- TD 9: 75 at BEB (Sidewinder)

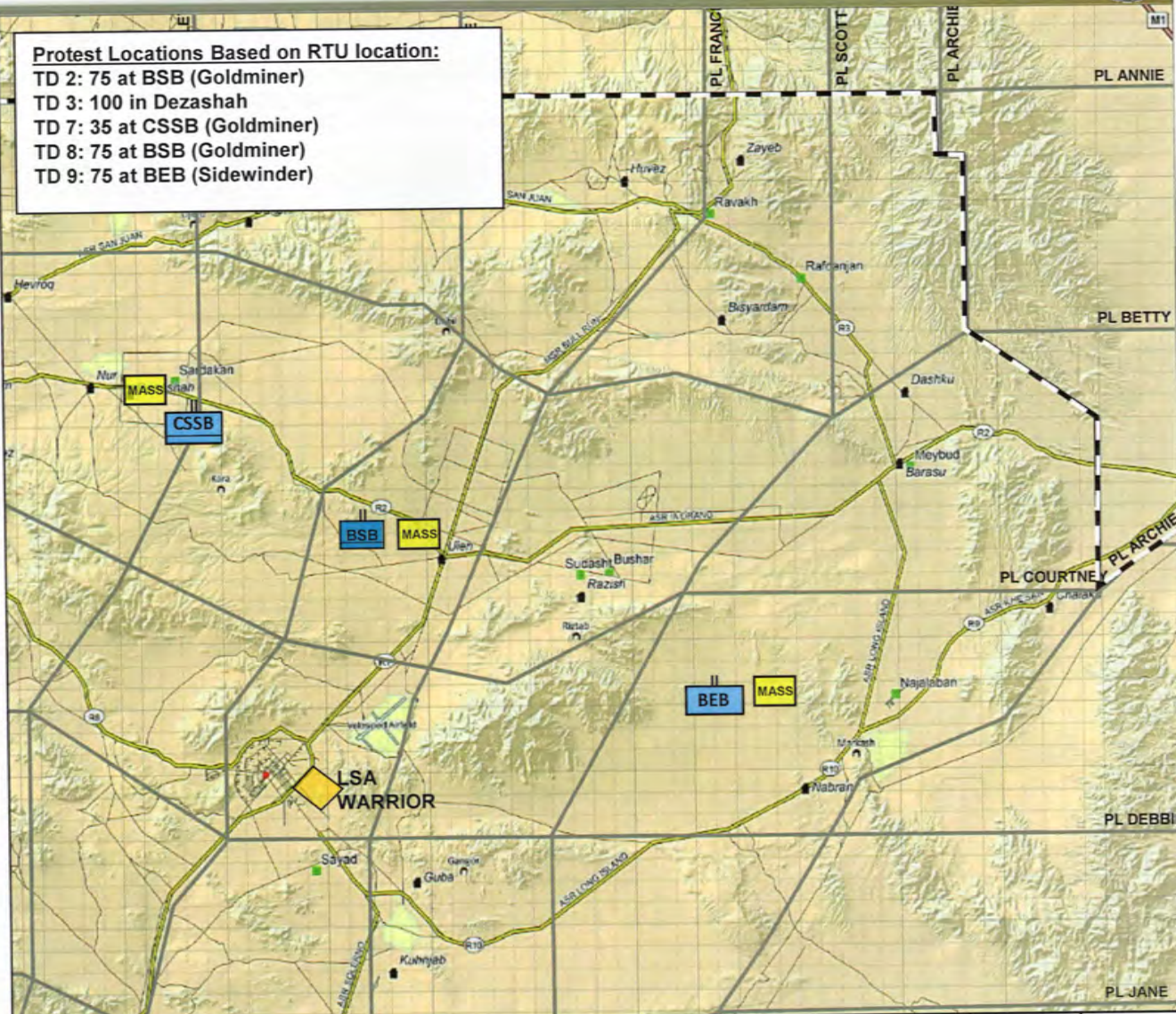

OCT/NOV	26	27	28	29	30	31	1	2	3
TD	1	2	3	4	5	6	7	8	9
EVENT		MASS	MASS				MASS	MASS	MASS



# IDP Movements



## CONCEPT

**COB Task:** Disrupt US forces in Atropia

**Purpose:** Escape the battlefield, seek food, water, shelter, medical aide. Move to UN DC Camp in Swabrot.

IDPs from Atropia flee their cities and move towards the FLOT and across the Gorgas/Atropia border. The civilians are fleeing the battlefield and are seeking safety. The IDPs are in one group and are seeking food, water, and medical attention. Some IDPs have wounds and symptoms of CCHF. The RTU will need to support Host Nation and the UN in assembling and screening the IDPs for transport to the Atropian IDP camp in Swabrot.

**ROE:** The protesters will be disruptive and frustrated with US Forces but will not directly threaten the RTU. Some IDPs will carry printed enemy propaganda. Some IDPs are armed.

## IDP 1

**Route:** From Dezashah to Rayalem (Across border).

**Role player info:** 40x ATR/LEZGIN IDPs in one group. Some IDPs have wounds due to BFB violence. Some CCHF. Some IDPs are armed for self defense but will not threaten US forces. BH provide 4x ATR police officers to assist the RTU. RTU must request assistance through the UN.

**Intel:** IDPs may describe what they see along the route +W2X intel.

**Link up:** 0800 in Dezashah.

## IDP 2

**Route:** From Razish to FLOT, then FLOT to BSA

**Role player info:** 75x ATR/LEZGIN IDPs in one group. Some IDPs have wounds due to BFB violence. No CCHF. Some IDPs are armed for self defense but will not threaten US forces. BH provide 4x ATR police officers to assist the RTU. RTU must request police assistance through the PCOP.

**Intel:** IDPs may describe what they see along the route +W2X intel.

**Link up:** 0800 in Razish.

## IDP 3/4

**Route:** From Ujen to BSB, then from Nabran to FLOT.

**Role player info:** 35x ATR/LEZGIN IDPs in one group. Some IDPs have wounds due to BFB violence. No CCHF. Some IDPs are armed for self defense but will not threaten US forces. BH provide 4x ATR police officers to assist the RTU. RTU must request police assistance through the PCOP. **Intel:** IDPs may describe what they see along the route +W2X intel.

**Link up:** 1100: in Ujen.

## IDP Routes

TD 1 – 40 IDPs from Dezashah to Rayalem (Refugees)

TD 5 – 75 IDPs from Razish to FLOT, then BSA

TD 7 – 35 IDPs to BSA, then (COG DP) from Nabran to FLOT

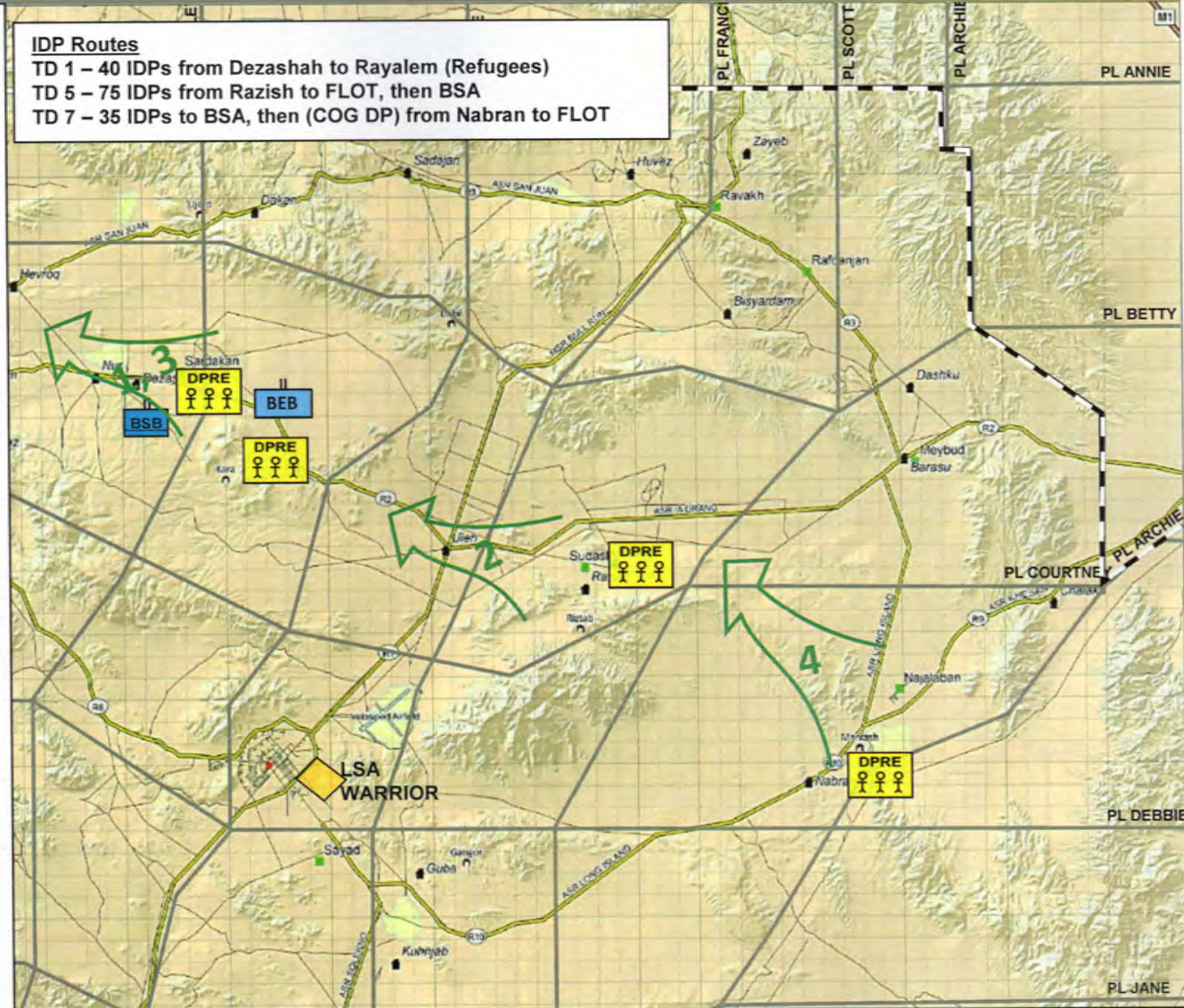

OCT/NOV	26	27	28	29	30	31	1	2	3
TD	1	2	3	4	5	6	7	8	9
EVENT	DPRE ☺☺☺				DPRE ☺☺☺		DPRE ☺☺☺		



## NOTES:

1. If you are unsure of your role/responsibility – contact your site manager and then L71 for clarification.
2. On site COR is Ms. Samantha Mendoza-Rodriguez (Approval Authority for hours and purchases). Phone: 760-380-3972.
3. Take all prudent measures to avoid driving through RTU and BH positions during force on force.
4. Stay safe, follow all safety protocols from range control and OCTs

CPT Michael McLean – Lizard 71B

Cell: 843-751-3774

Email: michael.a.mclean32.mil@mail.mil

# Questions?



*Lead, Train, Win!*